

NEMA Standards Publication VE 2-2013
With Errata
Cable Tray Installation Guidelines

Endorsed by Cable Tray Institute
www.cabletrays.com

Published by:

National Electrical Manufacturers Association
1300 North 17th Street, Suite 900
Rosslyn, Virginia 22209

www.nema.org

© 2013 National Electrical Manufacturers Association. All rights, including translation into other languages, reserved under the Universal Copyright Convention, the Berne Convention for the Protection of Literary and Artistic Works, and the International and Pan American copyright conventions.

NOTICE AND DISCLAIMER

The information in this publication was considered technically sound by a consensus among persons engaged in its development at the time it was approved. Consensus does not necessarily mean there was unanimous agreement among every person participating in the development process.

The National Electrical Manufacturers Association (NEMA) standards and guideline publications, of which the document herein is one, are developed through a voluntary standards development process. This process brings together volunteers and/or seeks out the views of persons who have an interest in the topic covered by this publication. Although NEMA administers the process and establishes rules to promote fairness in the development of consensus, it does not write the documents, nor does it independently test, evaluate, or verify the accuracy or completeness of any information or the soundness of any judgments contained in its standards and guideline publications.

NEMA disclaims liability for any personal injury, property, or other damages of any nature, whether special, indirect, consequential, or compensatory, directly or indirectly resulting from the publication, use of, application, or reliance on this document. NEMA disclaims and makes no guaranty or warranty, express or implied, as to the accuracy or completeness of any information published herein, and disclaims and makes no warranty that the information in this document will fulfill any particular purpose(s) or need(s). NEMA does not undertake to guarantee the performance of any individual manufacturer's or seller's products or services by virtue of this standard or guide.

In publishing and making this document available, NEMA is not undertaking to render professional or other services for or on behalf of any person or entity, nor is NEMA undertaking to perform any duty owed by any person or entity to someone else. Anyone using this document should rely on his or her own independent judgment or, as appropriate, seek the advice of a competent professional in determining the exercise of reasonable care in any given circumstance. Information and other standards on the topic covered by this publication may be available from other sources, which the user may wish to consult for additional views or information not covered by this publication.

NEMA has no power, nor does it undertake to police or enforce compliance with the contents of this document. NEMA does not certify, test, or inspect products, designs, or installations for safety or health purposes. Any certification or other statement of compliance with any health- or safety-related information in this document shall not be attributable to NEMA and is solely the responsibility of the certifier or maker of the statement.

CONTENTS

	Page
FOREWORD	VII
SECTION 1 SCOPE	1
1.1 Scope.....	1
1.2 General.....	1
1.3 Definitions, Abbreviations, and Acronyms.....	1
1.4 References.....	3
1.4.1 Contacts.....	4
1.5 RECEIVING AND UNLOADING.....	4
SECTION 2 STORAGE	6
SECTION 3 INSTALLATION	7
3.1 Cable Tray Installation Locations	7
3.2 Common Tools for Installation.....	7
3.3 Support Installation.....	7
3.3.1 Cable Tray Supports.....	8
3.3.2 Wall and Cantilever Brackets	14
3.3.3 Floor and Roof Installations.....	15
3.3.4 Vertical Installations.....	15
3.3.5 Transverse Installations.....	16
3.4 Straight Section Installation	17
3.4.1 Straight Section Position	17
3.4.2 Expansion Splice Plates	18
3.4.3 Vertical Adjustable Splice Plates.....	20
3.4.4 Horizontal Adjustable Splice Plates.....	21
3.4.5 Cable Tray to Box or Floor Splice Plates	21
3.4.6 Offset-Reducing Splice Plates.....	22
3.4.7 Vertical Support Plates	23
3.4.1 Step-Down Splice Plates	23
3.4.1 End Plates	23
3.4.2 Single-Rail Cable Tray Fitting Connectors	23
3.5 Fittings Installation.....	24
3.5.1 Recommended Support Locations for Fittings	24
3.5.2 Extended Vertical Runs	26
3.5.3 Recommended Support Locations for Single-Rail and Wire Mesh Cable Trays	27
3.6 Field Modifications.....	27
3.6.1 Marking.....	27
3.6.2 Cutting	27
3.6.3 Drilling.....	29
3.6.4 Finish Touch-Up	29
3.6.5 Wire Mesh Fittings Fabrication	30
3.7 Accessories	30
3.7.1 Barrier Strips.....	30
3.7.2 Drop-Outs	32
3.7.3 Cable Channel to Cable Tray	32
3.7.4 Conduit to Cable Tray Adaptors.....	33
3.7.5 Covers and Clamps	33
3.8 Grounding and Bonding.....	35
3.8.1 Cable Tray Used as an Equipment Ground Conductor (EGC)	36
3.8.2 Cable Trays with Wire-Type Equipment Grounding Conductor (EGC) Installed	36
3.8.3 Check for Properly Sized EGC or Bonding Jumpers	37
3.8.4 How to Install Bonding Jumpers.....	39
3.9 Bonding to The Metal Frame of the Building and Earth	39

SECTION 4 INSTALLATION OF CABLE	40
4.1 General	40
4.2 Handling and Storage	40
4.3 Cable Tray Preparation	40
4.4 Cable Pulling Considerations	40
4.5 Pulling the Cable	41
4.6 Fastening Cables.....	42
4.7 Protecting Installed Cable.....	43
SECTION 5 MAINTENANCE.....	44
5.1 Inspection	44
5.2 Inactive or Abandoned Cables	44
5.3 Adding Cables	44
ANNEX A TYPICAL CABLE TRAY TYPES	45
A.1 Cable Ladders	45
A.2 Single-Rail Cable Trays.....	45
A.3 Solid-Bottom Cable Trays.....	46
A.4 Trough (Ventilated Cable Trays)	46
A.5 Wire Mesh Cable Tray.....	46
A.6 Channel Cable Trays.....	47

TABLES

	Page
Table 3-1 Fastener Torque	17
Table 3-2 Maximum Spacing between Expansion Joints that Provide for 250 mm (1 in) Movement**	19
Table 3-3 Quantity of Standard Cover Clamps Required	35
Table 3-4 Metal Area Requirements for Cable Tray Systems Used as Equipment Grounding Conductors (NEC Table 392.60(A)).....	38
Table 3-5 Minimum Size Equipment Grounding Conductors for Grounding Raceway and Equipment (NEC Table 250.122)	39

FIGURES

	Page
Figure 1-1 Correct.....	5
Figure 1-2 Not Correct—Except when Using Extended Forks for Skidded Bundles	5
Figure 1-3 Correct	5
Figure 1-4 Incorrect.....	5
Figure 3-1 Strut Nut.....	9
Figure 3-2 C-Channel Support.....	9
Figure 3-3 Strut Support.....	9
Figure 3-4 Angle Iron Support.....	9
Figure 3-5 Typical Strut Support Installation.....	9
Figure 3-6 Strut (Exploded View)	9
Figure 3-7 Hold Downs	10
Figure 3-8 Single Cable Tray Hanger	10

Figure 3-9 Double Cable Tray Hanger.....	10
Figure 3-10 Single Cable Tray Hanger	11
Figure 3-11 Double Cable Tray Hanger.....	11
Figure 3-12 Single Cable Tray Hanger	12
Figure 3-13 Center Hanger Support	12
Figure 3-14 Center Hanger Support	12
Figure 3-15 Single Channel Hanger	13
Figure 3-16 Double Channel Hanger.....	13
Figure 3-17 Multiple Splice Support.....	14
Figure 3-18 Rod through Spine Hanger.....	14
Figure 3-19 Clevis Hanger	14
Figure 3-20 Single Strut Cantilever Bracket.....	14
Figure 3-21 Gusset Cantilever Bracket.....	14
Figure 3-22 Fiberglass Cantilever Bracket.....	15
Figure 3-23 Single-Rail Direct Wall Mount.....	15
Figure 3-24 Single-Rail Clamp Wall Mount.....	15
Figure 3-25 Elevated Strut-Type Support	15
Figure 3-26 Underfloor Support Attached to Floor Pedestals.....	15
Figure 3-27 Single-Rail Floor Support	15
Figure 3-28 Vertical Threaded Rod Support.....	15
Figure 3-29 Vertical Gusset Cantilever Support	15
Figure 3-30 Vertical Threaded Rod Support.....	16
Figure 3-31 Vertical Gusset Cantilever Support	16
Figure 3-32 Horizontal Wall Mount	16
Figure 3-33 Horizontal Strut Support	16
Figure 3-34 Cable Tray Support Locations	17
Figure 3-35 Cable Tray Installation.....	18
Figure 3-36 Cable Tray Installation.....	18
Figure 3-37 Splice Plate Attachment	18
Figure 3-38 Expansion Splice Plate Attachment	18
Figure 3-39 Hold-Down and Guide Clamp Locations	19
Figure 3-40 Gap Setting of Expansion Splice Plate—25.4 mm (1 in) Gap Maximum*.....	20
Figure 3-41 Two-Bolt Vertical Adjustable Splice Plates.....	21
Figure 3-42 Single-Bolt Vertical Adjustable Splice Plates	21
Figure 3-43 Horizontal Adjustable Splice Plates.....	21
Figure 3-44 Cable Tray to Box/Floor Splice Plates.....	22
Figure 3-45 Cable Tray to Box Connector	22

Figure 3-46 Offset-Reducing Splice Plate.....	22
Figure 3-47 Vertical Support Plates	23
Figure 3-48 Step-Down Splice Plates	23
Figure 3-49 End Plate	23
Figure 3-50 Horizontal Tee or 90° Connector	23
Figure 3-51 Horizontal Cross Connector	23
Figure 3-52 Horizontal Hub	24
Figure 3-53 Vertical Tee or 90° Connector	24
Figure 3-54 Horizontal Elbows	25
Figure 3-55 Horizontal Tee	25
Figure 3-56 Horizontal Wye	25
Figure 3-57 Horizontal Cross	25
Figure 3-58 Reducer	25
Figure 3-59 Vertical Elbows (Side View).....	26
Figure 3-60 Vertical Tee (Side View).....	26
Figure 3-61 Vertical Cable Support.....	26
Figure 3-62 Vertical Cable Support.....	26
Figure 3-63 Marking the Flanges	27
Figure 3-64 Marking the Web of the Rail	27
Figure 3-65 Cutting with Hand-Held Hack Saw	28
Figure 3-66 Cutting with Bolt Cutters	28
Figure 3-67 Correct Cut	28
Figure 3-68 Correct Blades to Use	28
Figure 3-69 Correct Blade Placement.....	28
Figure 3-70 Incorrect Cut	29
Figure 3-71 Incorrect Blades to Use	29
Figure 3-72 Incorrect Blade Placement	29
Figure 3-73 Drilling with Drill Jigs.....	29
Figure 3-74 Drilling with Punched Side Rail.....	29
Figure 3-75 Drilling with Clamp and Side Rail	29
Figure 3-76 Typical Wire Mesh Fittings—Field-Fabricated.....	30
Figure 3-77 Barrier Strip—Straight Section	31
Figure 3-78 Barrier Strip—Horizontal Fitting.....	31
Figure 3-79 Barrier Strip—Vertical Fitting	31
Figure 3-80 Barrier Strip Application.....	31
Figure 3-81 Barrier Strip Attachment—Self-Drilling and Self-Tapping Screw	31
Figure 3-82 Barrier Strip Attachment—Clip	31

Figure 3-83 Barrier Strip Slice Barrier	32
Figure 3-84 Barrier Strip Splice—Installed.....	32
Figure 3-85 Ladder Drop-Out.....	32
Figure 3-86 Trough Drop-Out	32
Figure 3-87 Trough Drop-Out Bushing	32
Figure 3-88 Cable Tray to Channel.....	33
Figure 3-89 Channel to Ladder Tray Bracket.....	33
Figure 3-90 Installed Conduit to Cable Tray Adapter	33
Figure 3-91 Swivel Conduit to Cable Tray Adapter	33
Figure 3-92 Conduit to Cable Tray Adapter	33
Figure 3-93 Cable Tray Covers.....	34
Figure 3-94 Cable Tray Cover Clamps and Accessories.....	35
Figure 3-95 Expansion Splice Plates	36
Figure 3-96 Horizontal Adjustable Splice Plates.....	36
Figure 3-97 Discontinuous	36
Figure 3-98 Cable Tray Sections Vertical Adjustable Splice Plate	36
Figure 3-99 Grounding Clamps.....	37
Figure 3-100 Bonding Jumper Examples.....	39
Figure 4-1 Cable Installation	41
Figure 4-2 Pulling Eye.....	42
Figure 4-3 Pulling Bolt.....	42
Figure 4-4 Straight Roller (Top Mounted)	42
Figure 4-5 Triple Pulley Guide	42
Figure 4-6 90° Roller	42
Figure 4-7 Cable Ties—Vertical Application	43
Figure 4-8 Cable Ties—Horizontal Application	43
Figure A-1 I-Beam.....	45
Figure A-2 C-Channel Flange In	45
Figure A-3 C-Channel Flange Out	45
Figure A-4 Center Rail Cable Tray.....	45
Figure A-5 Single-Tier Wall Mount.....	45
Figure A-6 Multi-Tier Wall Mount	45
Figure A-7 Pan Flange In	46
Figure A-8 Pan Flange Out	46
Figure A-9 Corrugated Bottom.....	46
Figure A-10 Solid Sheet on Top of Ladder Rung.....	46
Figure A-11 Corrugated Bottom with Holes	46

Figure A-12 Pan with Louvers.....	46
Figure A-13 Tray with Close Rung Spacing.....	46
Figure A-14 Wire Mesh	46
Figure A-15 Ventilated Bottom.....	47
Figure A-16 Solid Bottom	47

FOREWORD

For Cable Tray Installers: NEMA VE 2-2013 (hereinafter referred to as NEMA VE 2) is intended as a practical guide for the proper installation of cable tray systems. Cable tray system design shall comply with *National Electrical Code*[®] (*NEC*[®]) Article 392, NEMA VE 1, and NEMA FG 1 and follow safe work practices as described in NFPA 70E.

NEMA VE 2 guidelines and information do not intend to cover all details or variations in cable tray systems nor provide for every possible installation contingency.

Construction Experience: It is recommended that the work described be performed by qualified persons familiar with standard electrical construction practices, electrical equipment, and safety of electrical wiring systems.

NEMA VE 2 guidelines are useful to engineers, contractors, and maintenance personnel. In future, NEMA VE 2 will be updated periodically to reflect evolving technology and construction techniques.

Comments and suggestions for the improvement of this document are encouraged. They should be sent to:

Senior Technical Director, Operations
National Electrical Manufacturers Association
1300 North 17th Street, Suite 900
Rosslyn, Virginia 22209

This is the fourth edition of NEMA VE 2.

NEMA VE 2 was developed by the NEMA Cable Tray Section. Section approval does not necessarily imply that all section members voted for approval or participated in development. At the time NEMA VE 2 was approved, the NEMA Cable Tray Section consisted of the following members:

- ABB/Thomas & Betts Corp.—Memphis, TN
- Atkore International/Cope—Harvey, IL
- Chalfant Manufacturing Co.—Brunswick, OH
- Eaton Cooper B-Line—Highland, IL
- Legrand/Cablofil, Inc.—Mascoutah, IL
- MP Husky Corp.—Greenville, SC
- Snake Tray, Inc.—Bay Shore, NY
- Wiremaid Products Division—
Coral Springs, FL

< This page intentionally left blank. >



Section 1 SCOPE

1.1 SCOPE

NEMA VE 2 addresses shipping, handling, storing, and installing cable tray systems and provides information on maintenance and system modification.

1.2 GENERAL

WARNING!—Do not use a cable tray as a walkway, ladder, or support for people; cable tray is a mechanical support system for cables and raceways. Using cable trays as walkways can cause personal injury and can damage cable tray and installed cables.

Hazardous voltages in electrical equipment can cause severe personal injury or death. Safety-related work practices, such as those described in NFPA 70E or CSA Z462, as well as all applicable OSHA regulations should be followed at all times.

Performance of a cable tray wiring system depends on proper installation, including supports and cables. Neglecting installation and maintenance guidelines may lead to personal injury as well as damage to property.

Installation and maintenance of cable tray wiring systems shall be conducted only by qualified personnel. For the purposes of this guideline, a qualified person is one who is familiar with electrical construction. In addition, that person is:

- a) Trained and authorized to test, energize, clear, ground, tag, and lock out circuits, in accordance with established safety practices, and
- b) Trained in the proper care and use of protective equipment, such as insulated rubber gloves, hard hats, safety glasses or face shields, dust masks, and flash-resistant clothing, in accordance with established safety practices.

1.3 DEFINITIONS, ABBREVIATIONS, AND ACRONYMS

The following definitions, abbreviations, and acronyms appear in NEMA VE 2 or NEMA VE 1.

accessory: Components used to supplement the function of a straight section or fitting. Examples include, but are not limited to, dropout, cover, conduit adapter, hold-down device, and divider.

cable tray support span: The distance between the centerlines of supports.

cable tray system: A section or assembly of sections, and associated fittings, forming a mechanical system used to support cables and raceways.

channel cable tray: A fabricated structure consisting of a one-piece ventilated- or solid-bottom channel section.

classified: Indicates that a product has been evaluated to meet a specific purpose, e.g., classified as to its suitability for use as an equipment grounding conductor.

connector: A component that joins any combination of cable tray straight sections and fittings.

NOTE: The basic types of connectors include rigid, expansion, adjustable, and reducer. The term "splice" is also used in the industry to describe a connector.

degrees Celsius (°C)

degrees Fahrenheit (°F)

electromagnetic interference (EMI)

electrostatic discharge (ESD)

equipment grounding conductor (EGC)

fasteners: Screws, nuts, bolts, washers, rivets, spacers, pins, and other items used to connect and assemble cable tray systems.

fill depth: The vertical interior dimension of a cable tray that is used to calculate the allowable interior cross-sectional area.

fitting: A component that is used to change the size or direction of a cable tray system.

hot dipped galvanized after fabrication (H.D.G.A.F.)

horizontal cross: A fitting that joins cable trays in four directions at 90° intervals in the same plane.

horizontal elbow: A fitting that changes the direction of cable tray in the same plane.

horizontal tee: A fitting that joins cable trays in three directions at 90° intervals in the same plane.

horizontal wye: A fitting that joins cable trays in three directions at other than 90° intervals in the same plane.

ladder cable tray: A fabricated structure consisting of two longitudinal side rails connected by individual transverse members (rungs).

less than truckload (LTL)

radio frequency interference (RFI)

reducer: A fitting that joins cable trays of different widths in the same plane.

left-hand reducer: A reducer having, when viewed from the large end, a straight side on the left.

right-hand reducer: A reducer having, when viewed from the large end, a straight side on the right.

straight reducer: A reducer having two symmetrical offset sides.

single-rail cable tray: A fabricated structure consisting of a longitudinal rail with transversely connected members (rungs) that project from one side (side-supported) or both sides (center-supported), which may be single- or multi-tier.

solid-bottom or non-ventilated cable tray: A fabricated structure consisting of a bottom without ventilation openings within integral or separate longitudinal side rails.

straight section: A length of cable tray that has no change in direction or size.

support: A component that provides a means for supporting a cable tray, including, but not limited to, cantilever bracket, trapeze, and individual rod suspension.

trough or ventilated cable tray: A fabricated structure consisting of integral or separate longitudinal rails and a bottom having openings sufficient for the passage of air, fumes and vapors, and for heat dissipation. ~~and utilizing 75% or less of the plan area of the surface to support cables where the maximum open spacings between cable support surfaces of transverse elements do not exceed 100 millimeter (mm) (4 inch (in)) in the direction parallel to the tray side rails.~~

NOTES:

a) Trough or ventilated cable tray should conform to NEMA VE-1, Section 2.

~~a)b)~~ On horizontal bends only, the maximum distance between transverse elements is measured at the centerline of the bend.

~~b)c)~~ A ladder cable tray having rung spacing such that the cable tray meets the definition described above is considered to be a ventilated cable tray.

vertical elbow: A fitting that changes the direction of cable tray to a different plane.

inside vertical elbow: A fitting that changes the direction of cable tray upward from the horizontal plane.

outside vertical elbow: A fitting that changes the direction of cable tray downward from the horizontal plane.

vertical tee: A fitting that joins cable trays in three directions at 90° intervals in different planes.

wire mesh cable tray: A manufactured wire mesh tray consisting of steel wires welded at all intersections. Longitudinal wires located on the exterior of the tray are spaced at a maximum of 50 mm (2 in), and transverse wires are spaced at a maximum of 100 mm (4 in).

Note: Wire grid dimensions and wire placement location should be sized accordingly as set forth in NEMA VE-1, specifically Sections 4 Construction and Section 5 Tests.

wire mesh cable tray fitting: A fitting for wire mesh cable tray systems, fabricated from wire mesh cable tray straight sections. The fitting is field-constructed and attached to the adjacent sections using splice connectors in accordance with the manufacturer's instructions.

1.4 REFERENCES

At the time of publication, the editions indicated were valid. All standards are subject to revision, and parties to agreements based on this standard are encouraged to investigate the possibility of applying the most recent editions of the standard listed.

ASTM A123, *Standard Specification for Zinc (Hot-Dip Galvanized) Coatings on Iron and Steel Products*

ASTM A653, *Standard Specification for Steel Sheet, Zinc-Coated (Galvanized) or Zinc-Iron Alloy-Coated (Galvannealed) by the Hot-Dip Process*

ASTM A780, *Standard Practice for Repair of Damaged and Uncoated Areas of Hot-Dip Galvanized Coatings*

ASTM B633, *Standard Specification for Electrodeposited Coatings of Zinc on Iron and Steel*

CEC Part 1, *Canadian Electrical Code Part 1: Safety Standard for Electrical Installations*

NEMA FG 1-1993, *Fiberglass Cable Tray Systems*

NEMA VE 1-2009/CSA 22.2 No. 126.1-09, *Metal Cable Tray Systems*

NFPA 70, *National Electrical Code*, 2011

NOTE: Referenced as NEC.

NFPA 70E, *Standard for Electrical Safety in the Workplace*

1.4.1 Contacts

1.4.1.1 ASTM International

For information concerning ASTM, contact:

ASTM International
100 Barr Harbor Drive, PO Box C700
West Conshohocken, PA, 19428-2959
www.astm.org

1.4.1.2 CSA Group

For information concerning CSA Group (or CEC), contact:

CSA Group
178 Rexdale Blvd.
Toronto, ON Canada M9W 1R3
www.csagroup.org

1.4.1.3 National Electrical Manufacturers Association (NEMA)

For information concerning NEMA, contact:

National Electrical Manufacturers Association
1300 North 17th Street, Suite 900
Rosslyn, VA 22209-3801
www.nema.org

1.4.1.4 National Fire Protection Association (NFPA)

For information concerning NFPA, contact:

NFPA
1 Batterymarch Park
Quincy, MA 02169-7471
www.nfpa.org

1.5 RECEIVING AND UNLOADING

Cable tray is generally bundled and shipped via motor freight, except for export shipments that could be crated or loaded in containers. Accessories and small components are boxed and often skidded.

Cable tray can be shipped via enclosed van, trailer, or flatbed trailer. Van trailers are normally used for less than truckload (LTL) shipments. This method of shipment is most common and cost effective and offers maximum protection from the weather during shipment. LTL shipments should be hand unloaded unless provisions have been made with the cable tray manufacturer for forklift unloading.

Flatbed trailers are often used for full truckload shipments and when customers want side forklift unloading or sling unloading by crane. (Special care must be exercised using slings so that cable tray is not crushed as a result of improper sling location and lifting.) See Figure 1-1 and Figure 1-2.

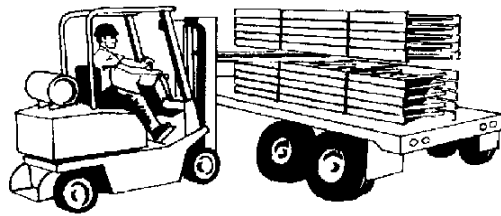

Figure 1-1 Correct



Figure 1-2 Not Correct—Except when Using Extended Forks for Skidded Bundles

Small to medium size orders less than 600 meters (m) (2,000 feet (ft)) are generally shipped via common carrier, LTL in enclosed vans.

If hand unloaded, workers should wear gloves.

To prevent damage to cable tray, never pull cable tray from a truck trailer by chaining to the bottom rung and dragging cable tray out of the trailer (see Figure 1-3 and Figure 1-4).

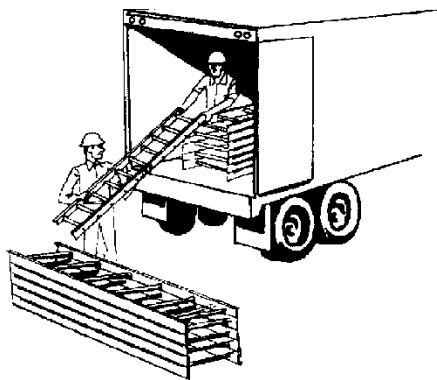

Figure 1-3 Correct

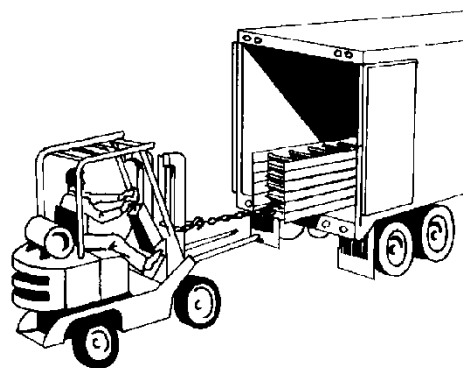

Figure 1-4 Incorrect

After unloading, inventory all items immediately using the manufacturer's packing list. Note on the bill of lading any shortage or shipping damage. That information will be necessary if filing a freight claim.

Section 2 STORAGE

Hot dipped galvanized after fabrication (H.D.G.A.F.) (see ASTM A123) steel, aluminum, and stainless steel cable tray and fiberglass or other non-metallic cable tray can be stored outside without cover, but should be loosely stacked, elevated off the ground, and ventilated to prevent storage stain. If appearance is important, cable tray should be stored indoors to prevent water or other foreign materials from staining or adhering to cable tray.

Mill-galvanized (see ASTM A653) or electro-galvanized (see ASTM B633) cable tray must be protected or stored in a well-ventilated, dry location.

Bare steel cable tray should receive a protective coating as soon as possible to prevent surface rust.

PVC or painted cable tray should be protected and stored indoors if possible. Cable tray must be protected from scratching and marring of the finish.

Small accessories should be stored to prevent loss.

Cable tray should be stored away from high-traffic areas.

Cable tray should be stacked by width and type.



Section 3 INSTALLATION

For Cable Tray Installers: NEMA VE 2 is intended as a practical guide for the proper installation of cable tray systems. Cable tray system design shall comply with NEC Article 392, NEMA VE 1, and NEMA FG 1, and shall follow safe work practices as described in NFPA 70E.

These instructions and information are not intended to cover all details or variations in cable tray systems; nor are they intended to provide for every possible installation contingency.

Construction Experience: It is recommended that the work described be performed by qualified persons familiar with standard electrical construction practices, electrical equipment, and safety of electrical wiring systems.

3.1 CABLE TRAY INSTALLATION LOCATIONS

Where not allowed: NEC Article 392 states that cable tray systems shall not be installed in hoist ways or where subject to severe physical damage. Metal cable tray systems may support conductor types allowed in certain areas to include environmental air and classified locations. The restrictions apply to the conductors being installed, not the cable trays. Local codes apply.

Provide access: Cable tray systems are to be installed so that they are accessible. If possible, 300 mm (12 in) minimum should be left above or between installed systems to allow for cable installation and maintenance.

In possible fire areas: Cable tray installations should avoid possible fire areas. Should that not be possible, and if there are critical circuits involved, stainless steel cable tray and fire resistant cables should be considered. Wrapping cable tray in a flame-resistant blanket might create a cable-heating problem without a fire. Installing a physical fire shield beneath a cable tray system may provide only limited improvement and create other issues.

3.2 COMMON TOOLS FOR INSTALLATION

The following tools are commonly used for installation of cable tray:

- | | |
|---|------------------------------------|
| a) Metal cutting saw | j) Leveling device |
| b) Touch-up material | k) Tape measure |
| c) Screwdriver | l) Square |
| d) Drill with bits | m) C clamp |
| e) File | n) Torque wrench |
| f) Open-end wrench | o) Ratchet wrench |
| g) Nylon cord or laser | p) Offset bolt cutters (wire mesh) |
| h) Sealant for cut edges (fiberglass) | q) Dust mask (fiberglass) |
| i) Cutting saw (for fiberglass), carbide- or diamond-tipped | r) Appropriate safety equipment |

3.3 SUPPORT INSTALLATION

Caution! Do not cut or drill structural building members (e.g., I-beams) without approval by the general contractor.

To install the cable tray supports, first find the required elevation from the floor to the bottom of the cable tray, and establish a level line with a laser or a nylon string. A string works well because it can be used to align the threaded rods on one side of a trapeze and locate the tops of the supports.

To speed the process of installing the trapeze hangers, some nuts may be pre-threaded onto the threaded rod to the approximate location where the nut will be needed. One method for pre-threading the nuts is to put the nuts onto the end of a piece of threaded rod, attach a drill to the threaded rod, and run the nuts up the rod while holding them with an open end wrench.

NOTE: Non-metallic supports and hardware may require special load bearing considerations because of material composition and application temperature. Consult the cable tray manufacturer for recommended practices.

3.3.1 Cable Tray Supports

Caution! Supports for cable trays should provide strength and working load capabilities sufficient to meet the load requirement of the cable tray wiring system. Consideration should be given to loads associated with future cable additions (see Section 5.3) or any other additional loads applied to the cable tray system or the cable tray support system.

NOTE: Non-metallic supports and hardware may require special load bearing considerations because of material composition and application temperature.

NOTE: Special consideration may be required for center-supported systems, considering eccentric loading.

NOTE: Installations requiring seismic considerations affects the cable tray systems supports. The supports should be braced according to the relevant seismic zone. Contact the manufacturer for approved bracing information.

3.3.1.1 Trapeze Type

For examples of trapeze-type supports, see Figure 3-1 through Figure 3-7.

To install:

- a) Thread nuts onto threaded rod approximately 50 mm (2 in) above the desired location for the bottom of the cable tray.
- b) Slide on square washers followed by cross member and second set of square washers.
- c) Thread the second set of nuts onto the threaded rod.
- d) Move the cross member so that the top surface is located where the bottom of the cable tray run will be located.
- e) Move the second set of nuts up the threaded rod until the cross member is reached and held in place.
- f) Make sure the cross member is level, then move the first set of nuts down the threaded rod until the cross member is secured in place.

In most cases, hold-down guide clamps may be mounted on either the inside or outside of the cable tray side rail. When installed on the inside of the cable tray, the clamp and/or attaching hardware should not extend above the rung.

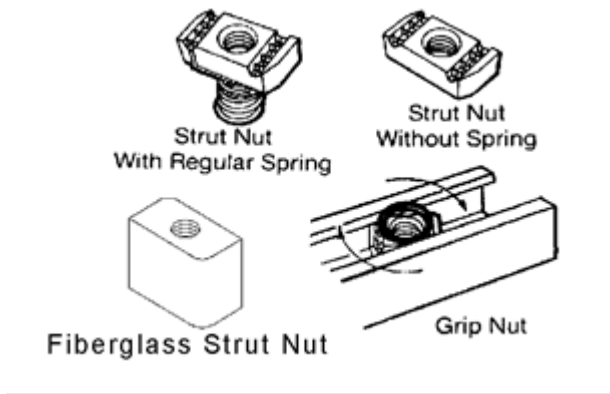

Figure 3-1 Strut Nut

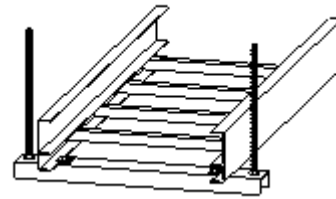

Figure 3-2 C-Channel Support

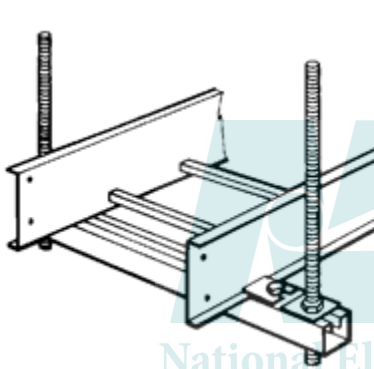

Figure 3-3 Strut Support

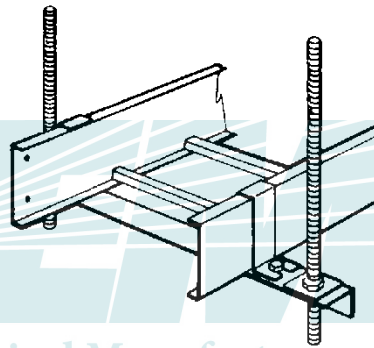

Figure 3-4 Angle Iron Support

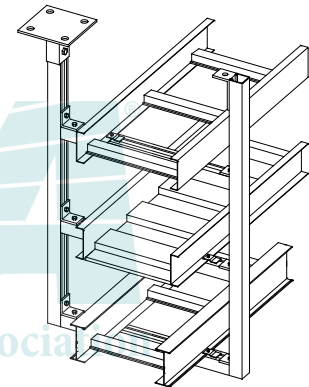
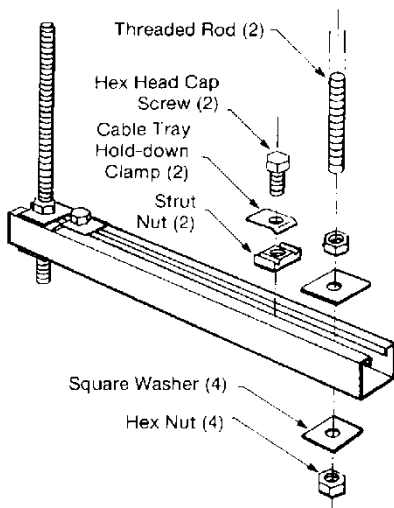

Figure 3-5 Typical Strut Support Installation

Figure 3-6 Strut (Exploded View)



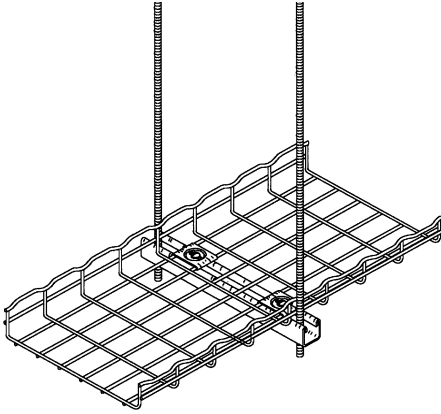

Figure 3-7 Hold Downs

3.3.1.2 Hanger Rod Clamp

For examples, see Figure 3-8 through Figure 3-12. To install:

- a) Thread nuts onto threaded rod approximately 225 mm (9 in) above the desired location for the bottom of the cable tray.
- b) Place a clamp around the side rail of the cable tray.
- c) Lift the entire cable tray section onto the threaded rod, running the threaded rod through the holes in the clamps.
- d) Thread a second set of nuts onto threaded rod, moving them up until the bottom of the cable tray reaches the desired location.
- e) Move the first set of nuts down the threaded rod and secure clamps in place.

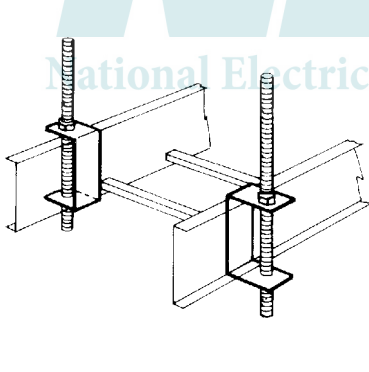

Figure 3-8 Single Cable Tray Hanger

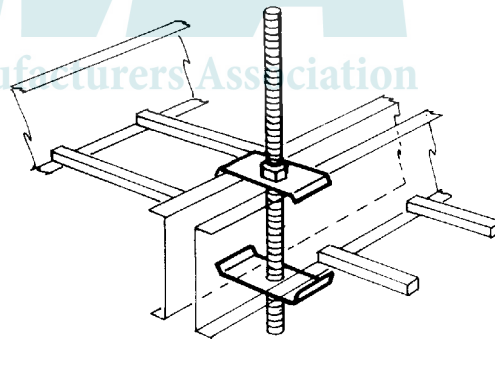

Figure 3-9 Double Cable Tray Hanger

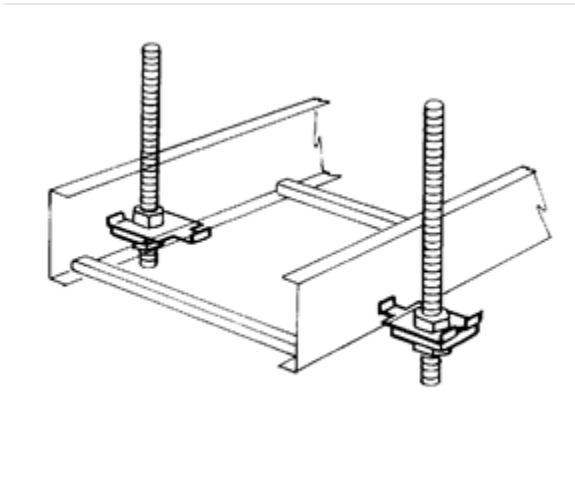

Figure 3-10 Single Cable Tray Hanger

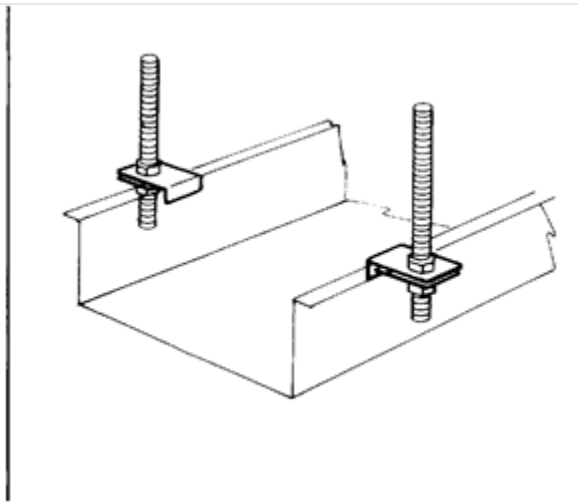

Figure 3-11 Double Cable Tray Hanger



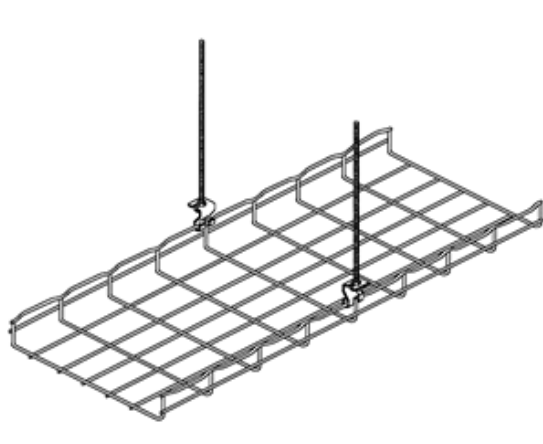

Figure 3-12 Single Cable Tray Hanger

3.3.1.3 Center Hung Support

For examples, see Figure 3-13 and Figure 3-14. To install:

- Thread nut onto threaded rod approximately 225 mm (9 in) above the desired location for the bottom of the cable tray.
- Slide washer and support onto the threaded rod with upright tube going through the center of the cable tray section needing support.
- Place a square washer on the threaded rod and thread on the second nut.
- Move cross member so its top surface is located at the place where the bottom of the cable tray run will be located.
- Move the second nut up the threaded rod until it reaches the cross member and holds it in place.
- Move the first nut down the threaded rod until it secures the cross member in place.

In most cases, hold-down/guide clamps may be mounted on either the inside or outside of the cable tray. When installed on the inside of the cable tray, the clamp and/or attaching hardware should not extend into the cable pathway.

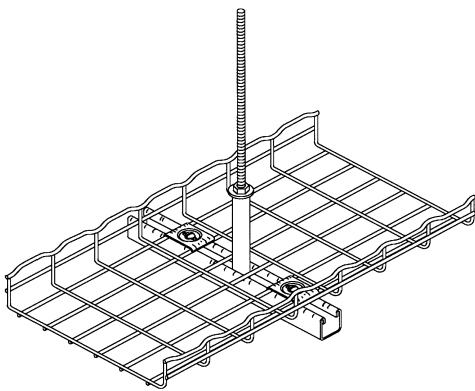

Figure 3-13 Center Hanger Support

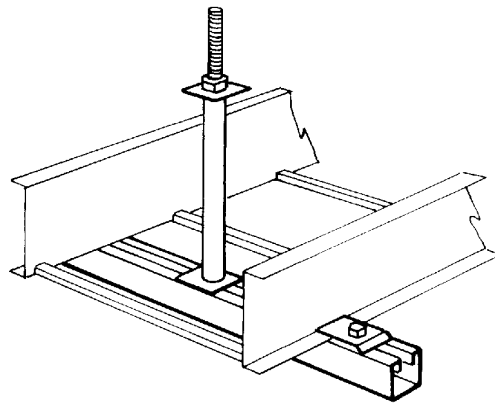

Figure 3-14 Center Hanger Support

3.3.1.4 Single Channel Cable Tray Hanger

For an example, see Figure 3-15. To install:

- a) Thread nut onto threaded rod to the height required.
- b) Place hanger on the threaded rod and follow with one nut.
- c) Run nut up the threaded rod until the bottom of the hanger is at the desired height.
- d) Run top nut down to tighten.
- e) Place channel on the hanger, and secure in place as necessary.

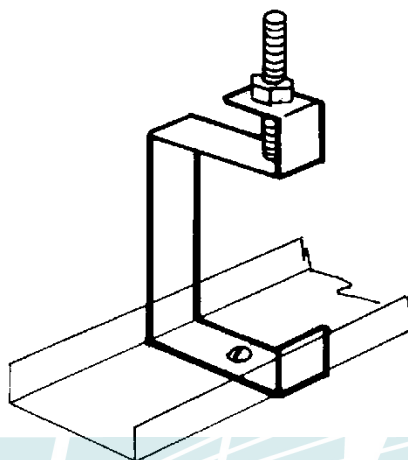

Figure 3-15 Single Channel Hanger

3.3.1.5 Double Channel Cable Tray Hanger

For an example, see Figure 3-16. To install:

- a) Thread nut onto threaded rod to the height required.
- b) Place the hanger on the threaded rod and follow with one nut.
- c) Run the nut up the threaded rod until the bottom of the hanger is at the desired height.
- d) Run the top nut down to tighten.
- e) Place channels on the hanger, and secure in place as necessary.

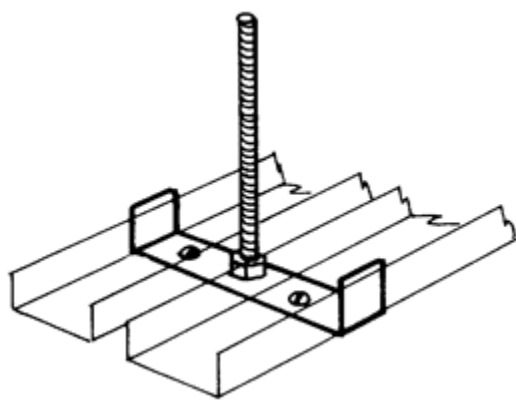

Figure 3-16 Double Channel Hanger

3.3.1.6 Single-Rail Cable Tray Hangers

For examples, see Figure 3-17 through Figure 3-19. To install:

- a) Thread nut onto threaded rod to the height required.
- b) Place the hanger or cable tray on the threaded rod and follow with one nut.
- c) Run the nut up the threaded rod until the bottom of the hanger or cable tray is at the desired height.
- d) Run the top nut down to tighten.
- e) Place the cable tray in the hanger, and secure in place as necessary.

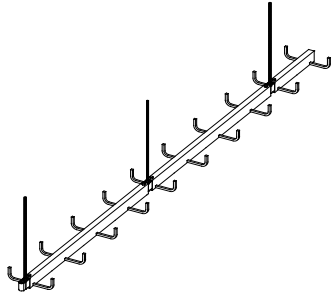

Figure 3-17 Multiple Splice Support

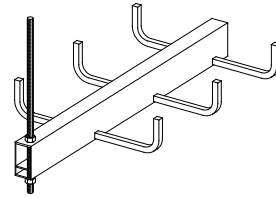

Figure 3-18 Rod through Spine Hanger

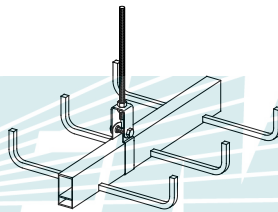

Figure 3-19 Clevis Hanger

3.3.2 Wall and Cantilever Brackets

For examples, see Figure 3-20 through Figure 3-24. Secure the brackets to the structure, making sure they are level and aligned with each other.

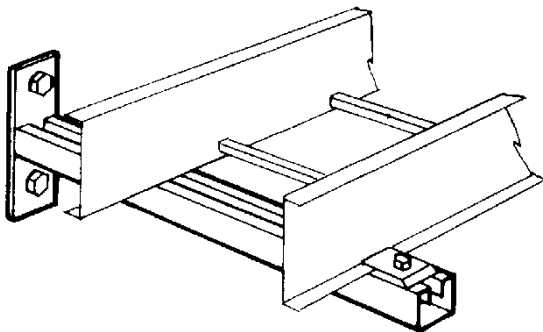

Figure 3-20 Single Strut Cantilever Bracket

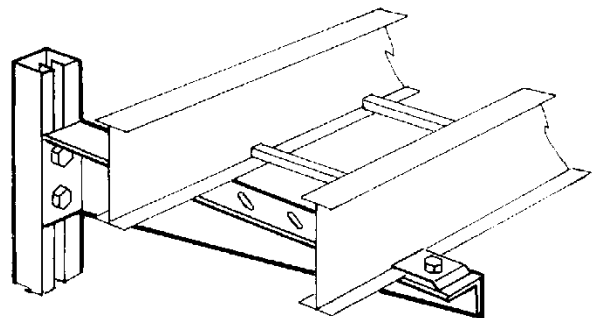

Figure 3-21 Gusset Cantilever Bracket

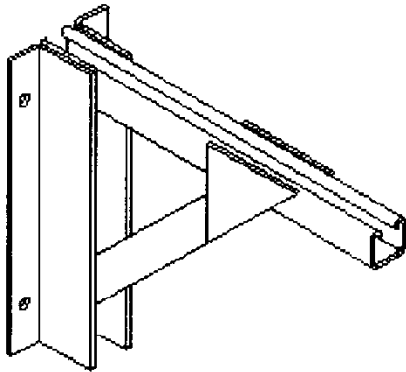

Figure 3-22 Fiberglass Cantilever Bracket

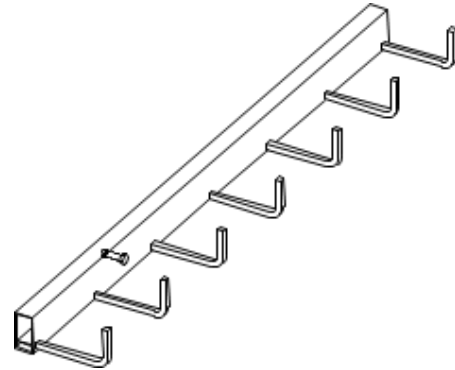

Figure 3-23 Single-Rail Direct Wall Mount

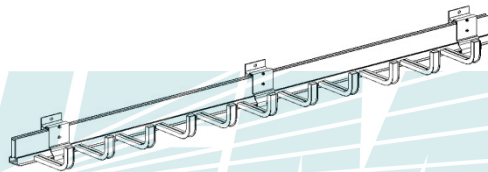

Figure 3-24 Single-Rail Clamp Wall Mount



3.3.3 Floor and Roof Installations

For examples, see Figure 3-25 through Figure 3-27. Cable tray should not be laid directly on the floor or roof. It should be mounted far enough off the floor or roof to allow the cables to exit through the bottom of the cable tray. If a strut is used for this purpose, mount the strut directly to the floor or roof and attach the cable tray to the strut using hold-down clamps and/or guide clamps.

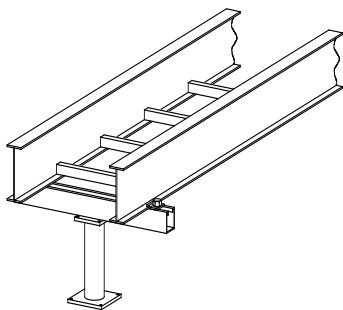

Figure 3-25 Elevated Strut-Type Support

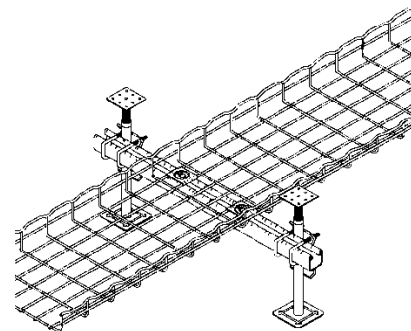

Figure 3-26 Underfloor Support Attached to Floor Pedestals

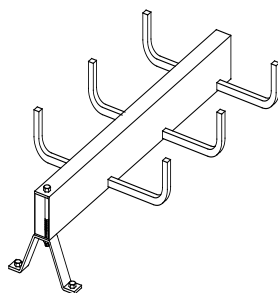

Figure 3-27 Single-Rail Floor Support

3.3.4 Vertical Installations

Similar to horizontal-type applications, vertical cable trays should be adequately supported. For examples, see Figure 3-28 through Figure 3-31. The cable tray should be supported on both the left and right side rails to the wall or support structure with appropriate hold-down clamps. Cable trays of less than 12 feet (ft) in length should be supported in a minimum of one location; and trays over 12 ft in length should be supported at a minimum of two locations. The cables should be secured to the rungs of the cable tray (see Section 4.6 b). Cable supports should be evenly spaced to distribute the load across the rung length. The vertical cable load should not be supported solely by the rungs on the top section of the run, but should be distributed evenly throughout the riser. For cable trays without rungs, contact the manufacturer for cable support guidance.

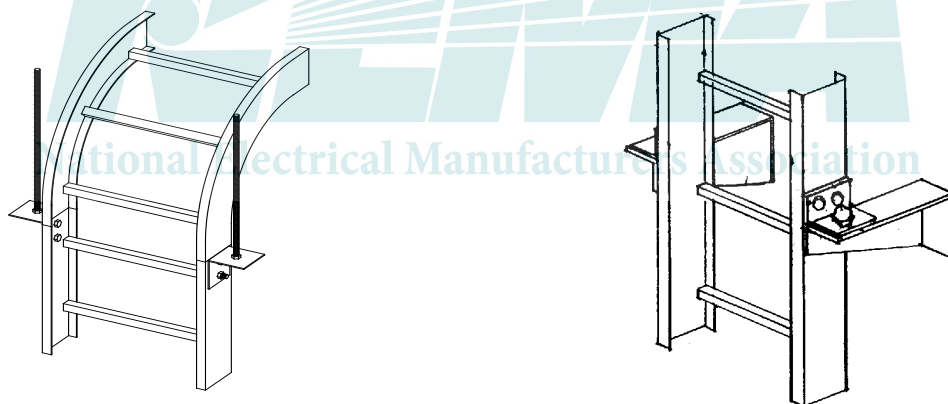

Figure 3-28 Vertical Threaded Rod Support

Figure 3-29 Vertical Gusset Cantilever Support

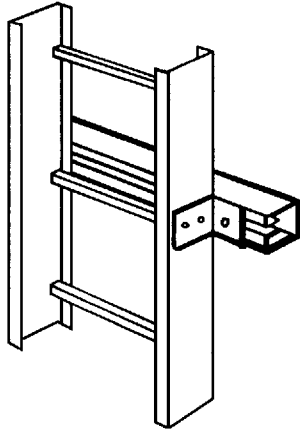

Figure 3-30 Vertical Threaded Rod Support

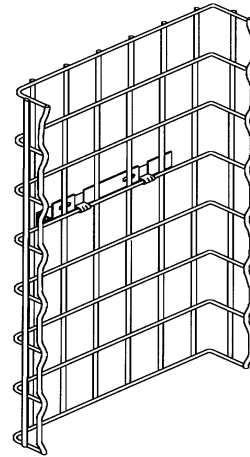

Figure 3-31 Vertical Gusset Cantilever Support

3.3.5 Transverse Installations

For examples, see Figure 3-32 and Figure 3-33. Similar to horizontal-type applications, transverse cable tray should be adequately supported. This is accomplished by securing the upper and lower rails to the wall or support structure with appropriate hold-down clamps. The cables should be secured to the rungs of the cable tray and evenly spaced to distribute the load across the rung length. The cable should not be allowed to collect or group along the bottom rail.

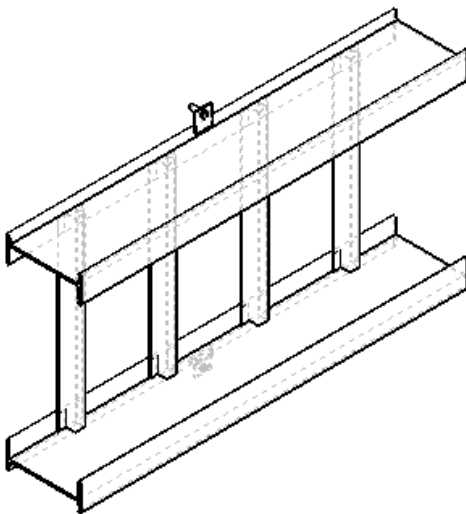
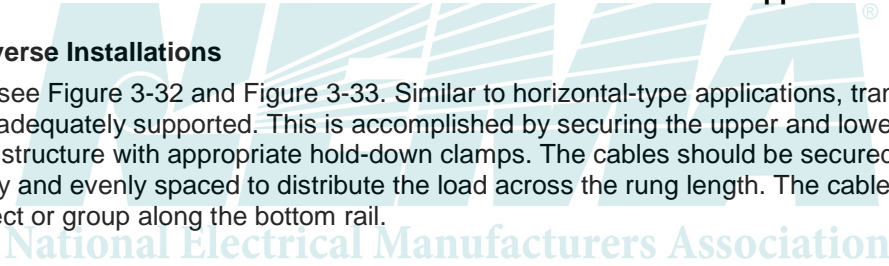

Figure 3-32 Horizontal Wall Mount

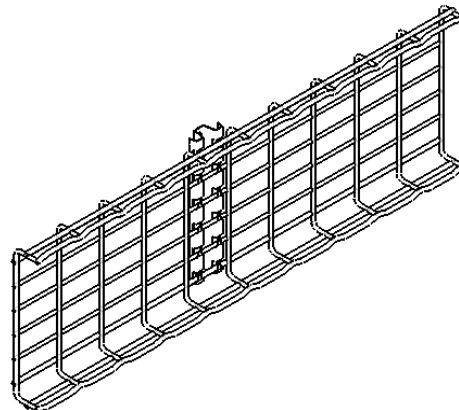

Figure 3-33 Horizontal Strut Support

3.4 STRAIGHT SECTION INSTALLATION

Use the torque data in Table 3-1 for fasteners. Follow the manufacturer's recommendations for non-metallic or non-ferrous fasteners. Torque values do not apply for hollow sections, such as tubes. Consult the manufacturer for recommendations.

Table 3-1 Fastener Torque

Inch: GRD. 2 UNC		Metric: Class 5.8	
Size	Ft-Lbs	Size	N-m
1/4 – 20	4-6	M8 x 1.25	14-16
3/8 – 16	17-23	M10 x 1.5	26-33
1/2 – 13	42-56	M12 x 1.78	45-58

NOTES:

- a) Threads are not lubricated.
- b) Fastener finishes: zinc-plated, cadmium-plated, and stainless steel

3.4.1 Straight Section Position

After the supports are in place, cable tray installation can begin at any convenient point. It is not necessary to start at one end of the run. Splice joints should be designed and placed so as to maximize the rigidity of the cable tray. Unless splice plates are part of a system specifically designed for other placement, including over supports or mid-span, it is ideal to lay out the system so that splice joints fall between the support and the quarter point (see Figure 3-34). When installing a 12-ft long section, for example, a support spacing of 3.7 m (12 ft) causes the splice joints to fall at the same position every time.

For single-rail cable tray, see Figure 3-17, Figure 3-23, and Figure 3-24.

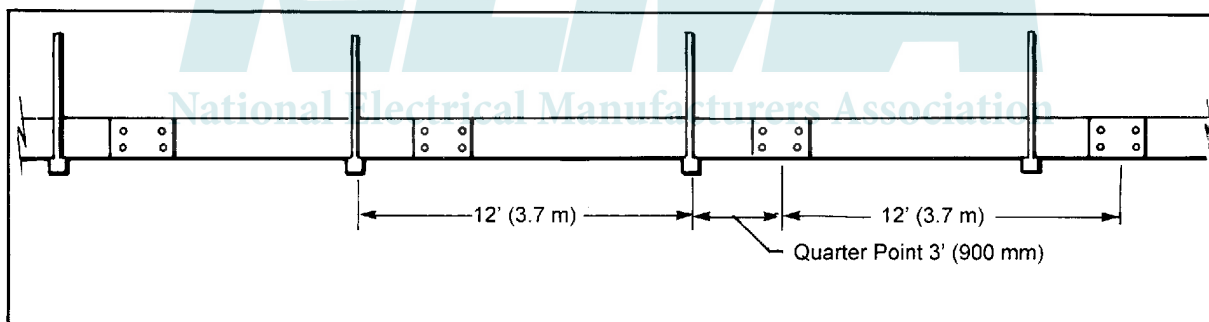

Figure 3-34 Cable Tray Support Locations

To begin, place a straight section across two supports so that the ends of the section are not directly on the support (see Figure 3-35). If the support span is equal to the length of the straight sections, bolt two pieces together for this step (see Figure 3-36). **The support span should not be greater than the straight section length, or as recommended by the manufacturer, to ensure that no more than one splice is located between supports.** Certain cable tray systems (see Figure 3-17) and certain splice designs allow for random splice location. See the manufacturer for details.

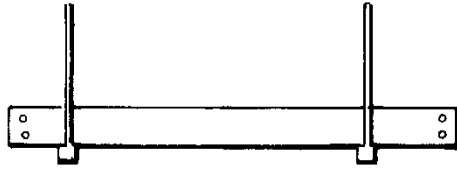

Figure 3-35 Cable Tray Installation

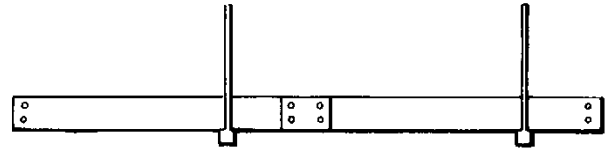

Figure 3-36 Cable Tray Installation

Place the next straight section across the next support, and attach it to the previous section with a pair of splice plates and hardware. The maximum tray overhang past the last support should not exceed 600 mm (2 ft). Splice plates should be placed on the outside of the cable tray, unless otherwise specified by the manufacturer, with the bolt heads on the inside of the cable tray (see Figure 3-37).

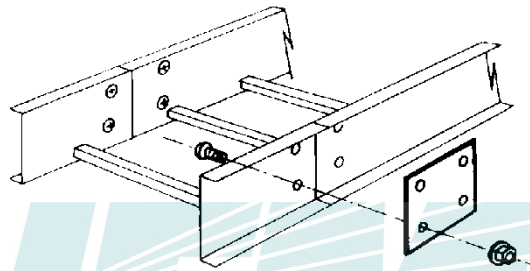

Figure 3-37 Splice Plate Attachment

3.4.2 Expansion Splice Plates

It is important to consider thermal contraction and expansion when installing cable tray systems. The length of the straight cable tray run and the temperature differential govern the number of expansion splice plates required (see Table 3-2 and, for an example, Figure 3-38).

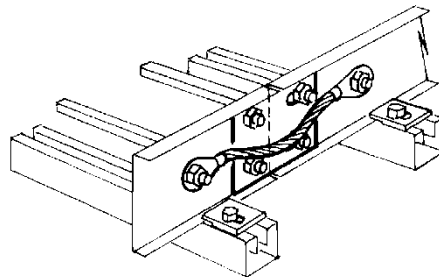

Figure 3-38 Expansion Splice Plate Attachment

NOTE: In Figure 3-38, a bonding jumper is not required for fiberglass cable tray systems.

Table 3-2 Maximum Spacing between Expansion Joints that Provide for 250 mm (1 in) Movement**

Temperature Differential*		Steel		Aluminum		Fiberglass	
°C	(°F)	m	(ft)	m	(ft)	m	(ft)
14	(25)	156	(512)	79	(260)	203	(667)
28	(50)	78	(256)	40	(130)	102	(333)
42	(75)	52	(171)	27	(87)	68	(222)
56	(100)	39	(128)	20	(65)	51	(167)
70	(125)	31	(102)	16	(52)	41	(133)
83	(150)	26	(85)	13	(43)	34	(111)
97	(175)	22	(73)	11	(37)	29	(95)

*Temperature differential is the difference in temperature between the hottest and coldest days of the year.

**For designs that provide for 16 mm (5/8 in) movement (typically non-metallic), multiply maximum spacing between expansion joints by 0.625.

The cable tray should be anchored at the support nearest to its midpoint between the expansion splice plates and secured by expansion guides at all other support locations (see Figure 3-39). The cable tray should be permitted longitudinal movement in both directions from that fixed point.

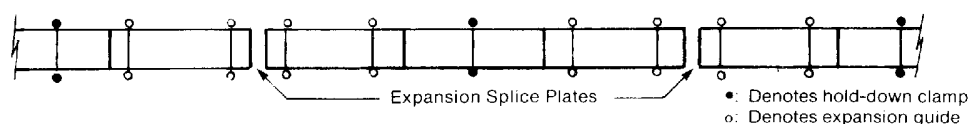

Figure 3-39 Hold-Down and Guide Clamp Locations

Accurate gap setting at the time of installation is necessary for proper operation of the expansion splice plates. The following procedure should assist the installer in determining the correct gap (see Figure 3-40):

- Plot the highest expected temperature on the maximum temperature line.
Example Value = 38°C (100°F)
- Plot the lowest expected temperature on the minimum temperature line.
Example Value = -33°C (-28°F)
- Draw a line between the maximum and minimum points.
- Plot the temperature at the time of installation to determine the gap setting.
Example Value = 9.5 mm (3/8 in), 10°C (50°F).

Special hardware is supplied with expansion splice plates. The nuts may have a stopping device (plastic stop nut). **Important:** For plastic stop nut designs, tighten hardware, then loosen 1/2 turn. For other types of hardware, follow the manufacturer's instructions.

Metal cable tray expansion joints require bonding for electrical continuity. Refer to Section 3.8 for bonding jumper installation (see Figure 3-38).

Supports should be located within 600 mm (2 ft) of each side of the expansion splice plates. Expansion splice joints should be designed and placed so as to maximize the rigidity of the cable tray, unless expansion splice plates are part of a system specifically designed for other placement, including over supports or mid-span.

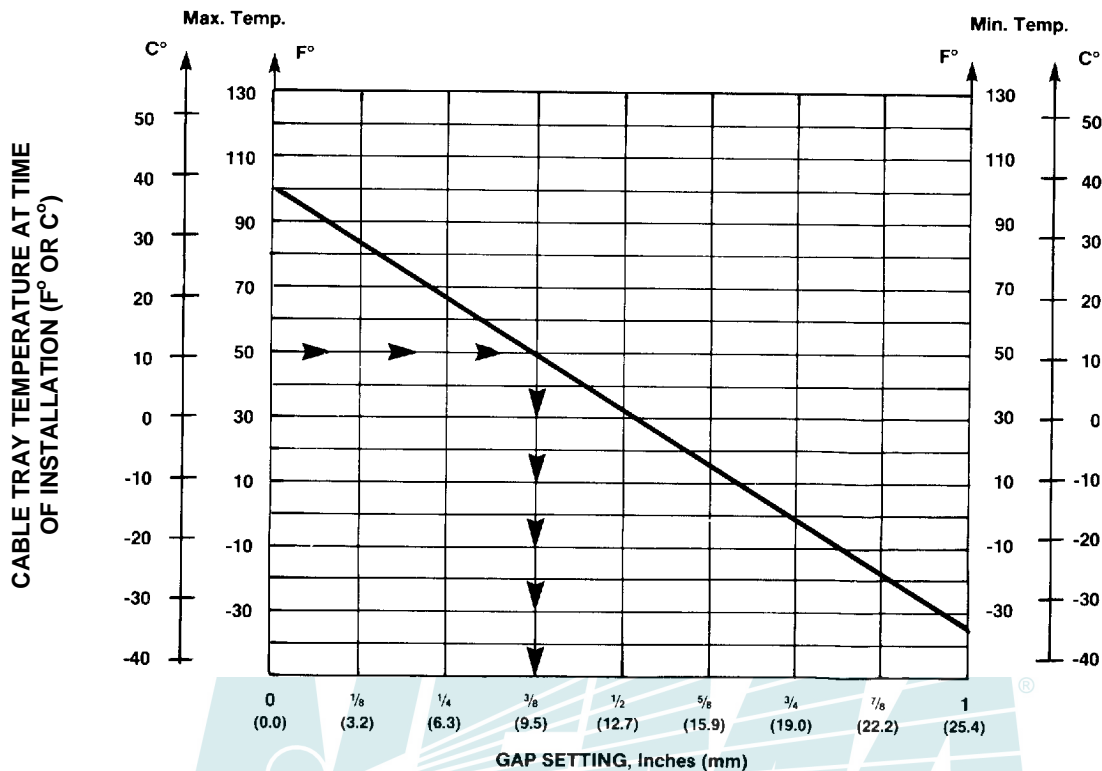

Figure 3-40 Gap Setting of Expansion Splice Plate—25.4 mm (1 in) Gap Maximum*

*For designs using 15.9 mm (5/8 in) maximum gap (typically non-metallic), multiply gap setting by 0.625.

NOTE: For extended vertical runs, see Section 3.5.2

3.4.3 Vertical Adjustable Splice Plates

For examples, see Figure 3-41 and Figure 3-42. For changes in vertical direction not requiring a radius, vertical adjustable splice plates can be used. Supports should be located within 600 mm (2 ft) of each side of vertical adjustable splice plates.

Vertical adjustable splice plates should be designed and placed so as to maximize the rigidity of the cable tray, unless vertical adjustable splice plates are part of a system specifically designed for other placement, including over supports or mid-span:

- Position splice halves so that offsets adjust for material thickness, and fasten with nut and bolt using hole (A).
- Attach to positioned cable tray sections, which sets the needed angle.
- Drill to complete hole (B). (Figure 3-41 only.)
- Insert and tighten all hardware.

For metal cable tray, bonding jumpers are required for electrical continuity, unless the splice plates meet the electrical continuity requirements of NEMA VE 1 Section 4.7. Also see Section 3.8.

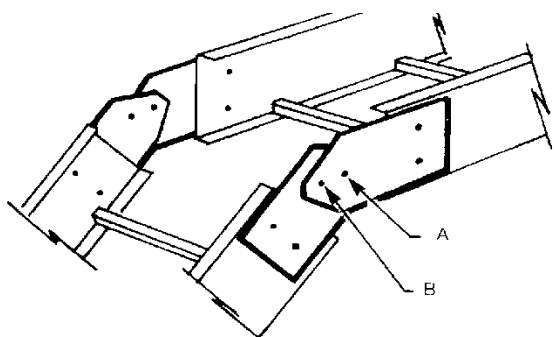

Figure 3-41 Two-Bolt Vertical Adjustable Splice Plates

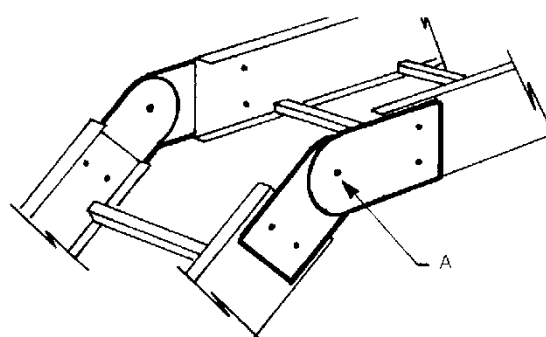

Figure 3-42 Single-Bolt Vertical Adjustable Splice Plates

3.4.4 Horizontal Adjustable Splice Plates

For changes in horizontal direction not requiring a radius, horizontal adjustable splice plates can be used. Supports should be located within 600 mm (2 ft) of each side of horizontal adjustable splice plates (see Figure 3-43).

Horizontal adjustable splice plates should be designed and placed so as to maximize the rigidity of the cable tray, unless horizontal adjustable splice plates are part of a system specifically designed for other placement, including over supports or mid-span:

- a) Connect inside connector (short piece), and position cable tray sections to set the angle.
- b) Position the outside connector, locating the hinge at mid-point.
- c) Drill required holes, and install and tighten all hardware.

For metal cable tray, bonding jumpers are required for electrical continuity unless the splice plates meet the electrical continuity requirements of NEMA VE Section 4.7, *Grounding*.

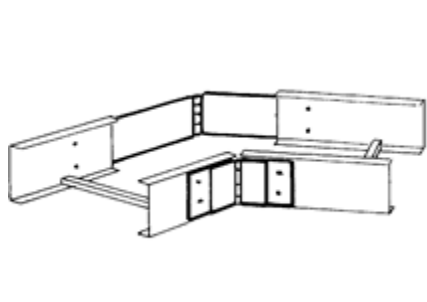

Figure 3-43 Horizontal Adjustable Splice Plates

3.4.5 Cable Tray to Box or Floor Splice Plates

For examples, see Figure 3-44 and Figure 3-45 (for termination of cable tray systems to equipment or structures).

Cable trays and/or cable penetrations through partitions, walls, floors, and ceilings often require special fire rating or environmental concerns and should be handled in accordance with NEC Articles 392 and 300.

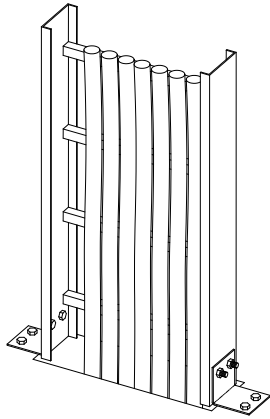

Figure 3-44 Cable Tray to Box/Floor Splice Plates

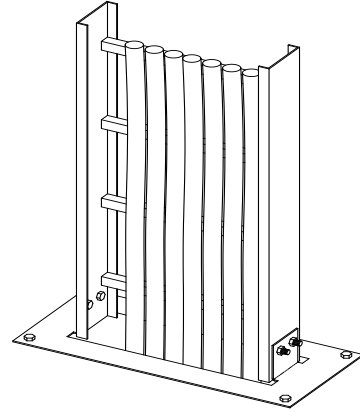

Figure 3-45 Cable Tray to Box Connector

3.4.6 Offset-Reducing Splice Plates

For immediate width changes, use offset-reducing splice plates. Supports should be located within 600 mm (2 ft) of each side of offset-reducing splice plates (see Figure 3-46):

- a) Use an offset-reducing splice plate with a standard splice plate to form an offset reduction.
- b) Use a pair of offset-reducing splice plates to form a straight reduction.

Offset-reducing splice plates should be designed and placed so as to maximize the rigidity of the cable tray, unless offset-reducing splice plates are part of a system specifically designed for other placement, including over supports or mid-span.

National Electrical Manufacturers Association

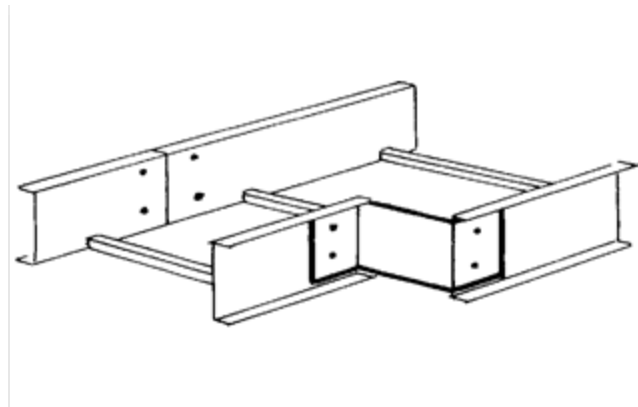

Figure 3-46 Offset-Reducing Splice Plate

3.4.7 Vertical Support Plates

For an example, see Figure 3-47 . Use vertical support splice plates for additional support of extended vertical runs (see Section 3.3.4).

3.4.1 Step-Down Splice Plates

For an example, see Figure 3-48. Use step-down splice plates when connecting cable trays of different heights. Step-down splice plates should be designed and placed so as to maximize the rigidity of the cable tray, unless step-down splice plates are part of a system specifically designed for other placement, including over supports or mid-span.

3.4.1 End Plates

For an example, see Figure 3-49. For dead-end closure indicating termination of cable tray run, use end plates.

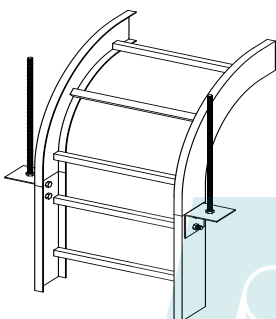

Figure 3-47 Vertical Support Plates

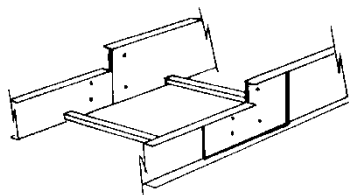

Figure 3-48 Step-Down Splice Plates

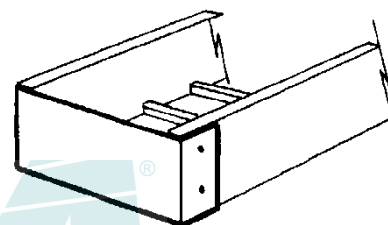

Figure 3-49 End Plate

3.4.2 Single-Rail Cable Tray Fitting Connectors

For examples, see Figure 3-50 through Figure 3-53. Single-rail cable trays typically use connector plates in lieu of radius fittings.

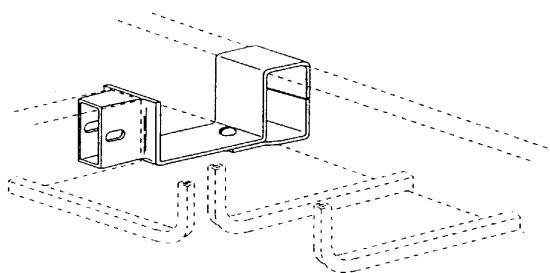

Figure 3-50 Horizontal Tee or 90° Connector

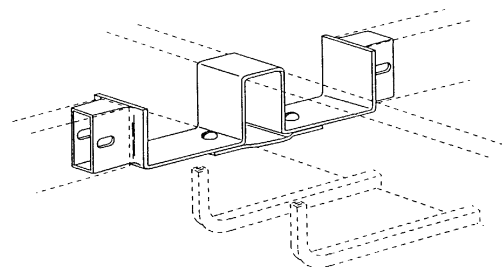

Figure 3-51 Horizontal Cross Connector

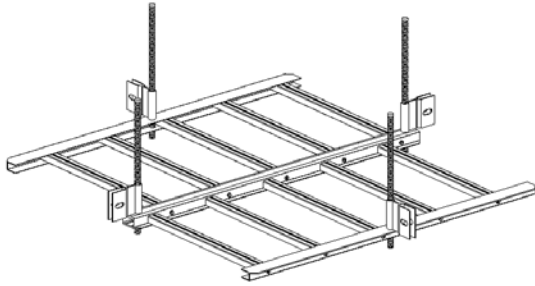

Figure 3-52 Horizontal Hub

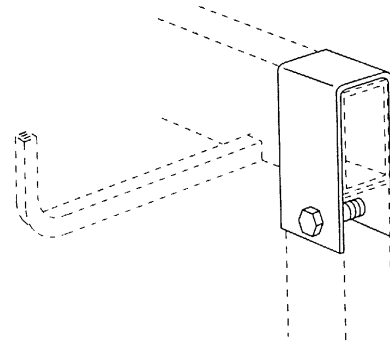

Figure 3-53 Vertical Tee or 90° Connector

3.5 FITTINGS INSTALLATION

See Section 3.5.3 for single-rail and wire mesh cable trays.

3.5.1 Recommended Support Locations for Fittings

Recommended support locations follow, unless otherwise recommended by the manufacturer.

3.5.1.1 Horizontal Elbow Support

For an example, see Figure 3-54. Supports for horizontal cable tray fittings should be placed within 600 mm (2 ft) of each fitting extremity, and as follows:

- 90° supports at the 45° point of arc.
- 60° supports at the 30° point of arc.
- 45° supports at the 22-1/2° point of arc (except for the 300 mm (12 in) radii, or smaller).
- 30° supports at the 15° point of arc (except for the 300 mm (12 in) radii, or smaller).

3.5.1.2 Horizontal Tee Support

For an example, see Figure 3-55. Place horizontal tee supports within 600 mm (2 ft) of each of the three openings connected to other cable tray items for the 300 mm (12 in) radius. On all other radii larger than 300 mm (12in), at least one additional support should be placed under each side rail at the horizontal tee, preferably as shown.

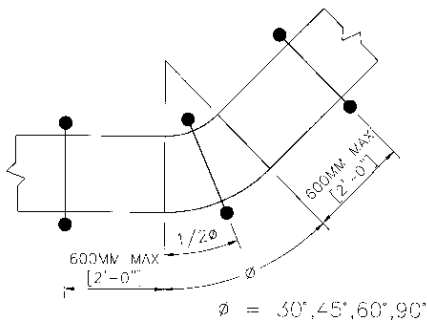

CENTER SUPPORT NOT REQUIRED
ON 12" RADIUS 30° & 45° FITTINGS

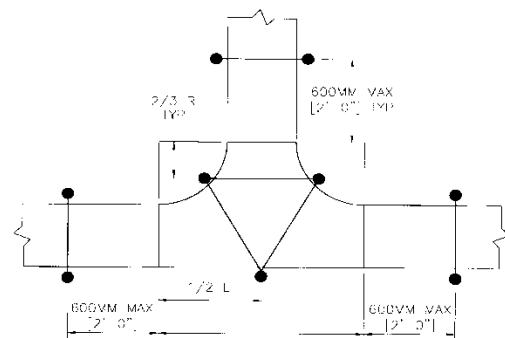

CENTER SUPPORT NOT REQUIRED ON 12" RADIUS FITTINGS

Figure 3-54 Horizontal Elbows

Figure 3-55 Horizontal Tee

3.5.1.3 Horizontal Wye Support

For an example, see Figure 3-56. Place horizontal wye supports within 600 mm (2 ft) of each of the three openings connected to other cable tray items, and at the 22-1/2° point of the arc adjacent to the side branch.

3.5.1.4 Horizontal Cross Support

For an example, see Figure 3-57. Place horizontal cross support within 600 mm (2 ft) of each of the four openings connected to other cable tray items for the 300 mm (12 in) radius. On all other radii, at least one additional support should be placed under each side rail of the horizontal cross, preferably as shown.

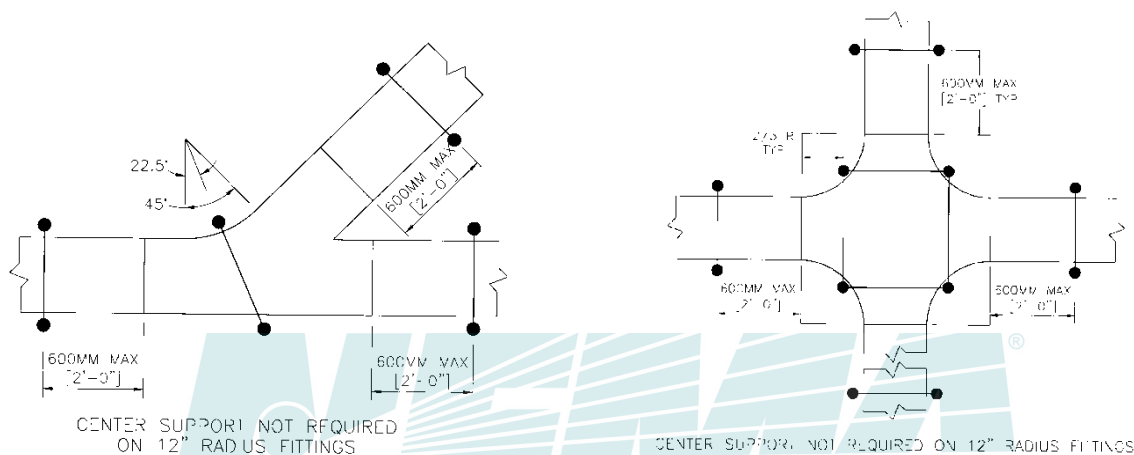

Figure 3-56 Horizontal Wye

Figure 3-57 Horizontal Cross

National Electrical Manufacturers Association

3.5.1.5 Reducer Support

For an example, see Figure 3-58. Place reducer supports within 600 mm (2 ft) of each fitting extremity.

3.5.1.6 Vertical Cable Tray Elbows

For an example, see Figure 3-59. Vertical cable tray elbows at the top of runs should be supported at each end. At the bottom of runs, they should be supported at the top of the elbow and within 600 mm (2 ft) of the lower extremity of the elbows.

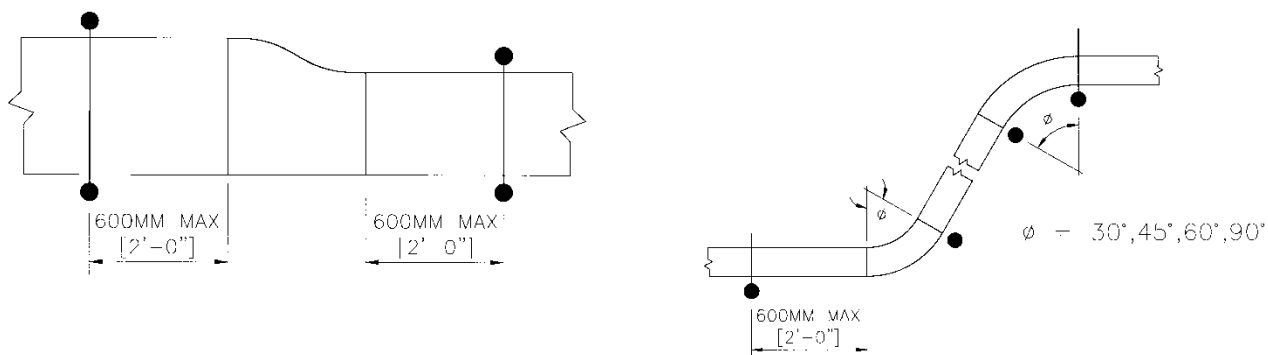

Figure 3-58 Reducer

Figure 3-59 Vertical Elbows (Side View)

3.5.1.7 Vertical Cable Tray Tees

For an example, see Figure 3-60. Vertical cable tray tees should be supported within 600 mm (2 ft) of each fitting extremity.

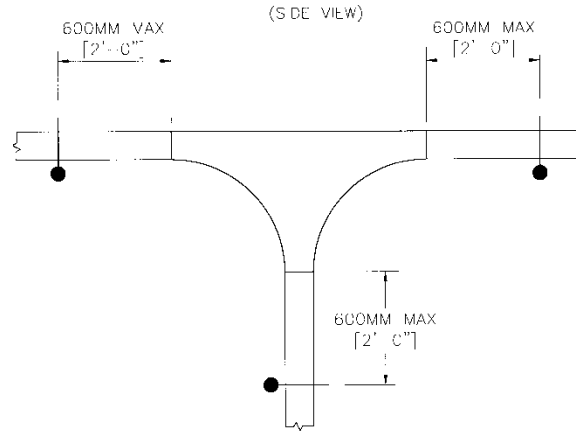

Figure 3-60 Vertical Tee (Side View)

3.5.2 Extended Vertical Runs

3.5.2.1 Cable Support Fittings

For examples, see Figure 3-61 and Figure 3-62. These fittings are recommended for use at the top of long vertical runs of heavy cable to support the cables.

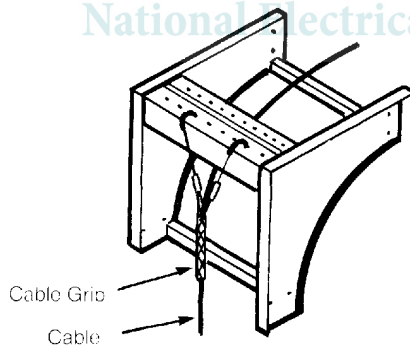

Figure 3-61 Vertical Cable Support

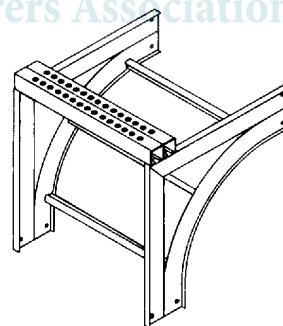

Figure 3-62 Vertical Cable Support

3.5.2.2 Securing and Allowing for Expansion

Extended vertical runs of cable tray that require accommodation for expansion may require installation modifications. If the system is outdoor and is supporting a sizable cable load, each section of cable tray may need to be securely attached to the structure with heavy duty bolt-through hold-down clamps. Bolt-through hold-down clamps of this type should anchor each cable tray section. Sections should be spaced apart (similar to the horizontal spacing provisions as identified in Figure 3-40) enough to allow for any possible expansion, and should be grounded using bonding jumpers connected to each section (see Figure 3-38).

3.5.3 Recommended Support Locations for Single-Rail and Wire Mesh Cable Trays

Single-rail and wire mesh cable trays have alternate support configurations. Consult the manufacturer for details.

3.6 FIELD MODIFICATIONS

Eventually it will be necessary to field cut the cable tray because the length of the cable tray required will be less than standard length. If there are many cuts to be made in a given area, waste can be prevented by making a cut list, which can be used to calculate the most efficient use of the standard sections.

Cable tray field modifications shall be made by qualified personnel only.

3.6.1 Marking

For examples, see Figure 3-63 and Figure 3-64. Using a square that reaches across the width of the cable tray, gauge off the edge of one side rail and mark both flanges (see Figure 3-63). Next, position the square as shown in Figure 3-64, and mark the web of the rail. Marking can be done with a scribe, marking pen, or a pencil.

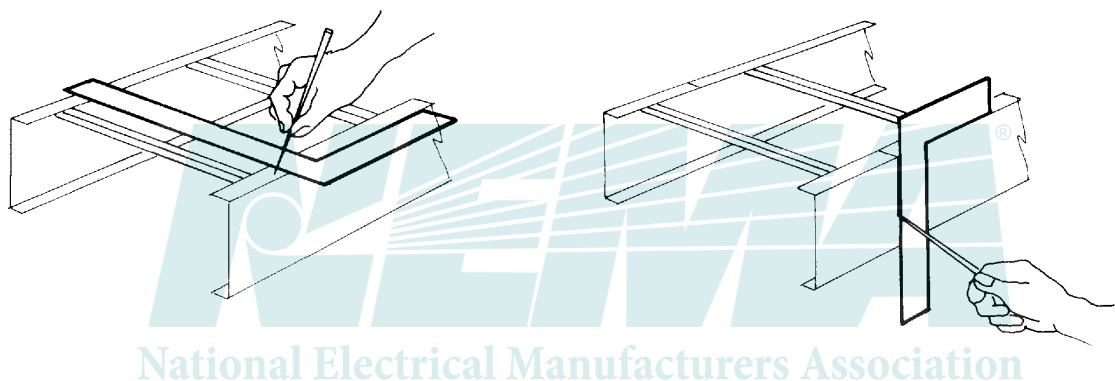

Figure 3-63 Marking the Flanges

Figure 3-64 Marking the Web of the Rail

3.6.2 Cutting

The cut can be made using a hand-held hack saw, a circular saw with carbide-tip or diamond-dusted blade, a hand-held band saw, offset bolt cutters, or a high-speed grinder (for wire mesh only). It is important to get a square cut to ensure a good splice connection. Cable tray manufacturers offer jigs and other devices to aid in field cutting (see Figure 3-65 and Figure 3-66). After cutting, smooth the cut edges to remove any burrs. Fiberglass material should be cut with a circular saw with a carbide tip or a diamond-dusted blade.

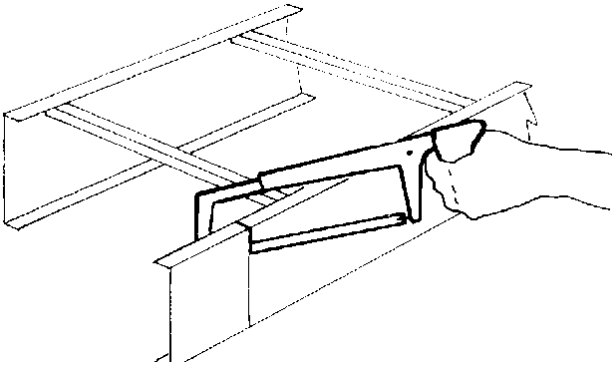

Figure 3-65 Cutting with Hand-Held Hack Saw



Figure 3-66 Cutting with Bolt Cutters

For examples of correct cut, correct blades to use, and correct blade placement, see Figure 3-67 through Figure 3-69.

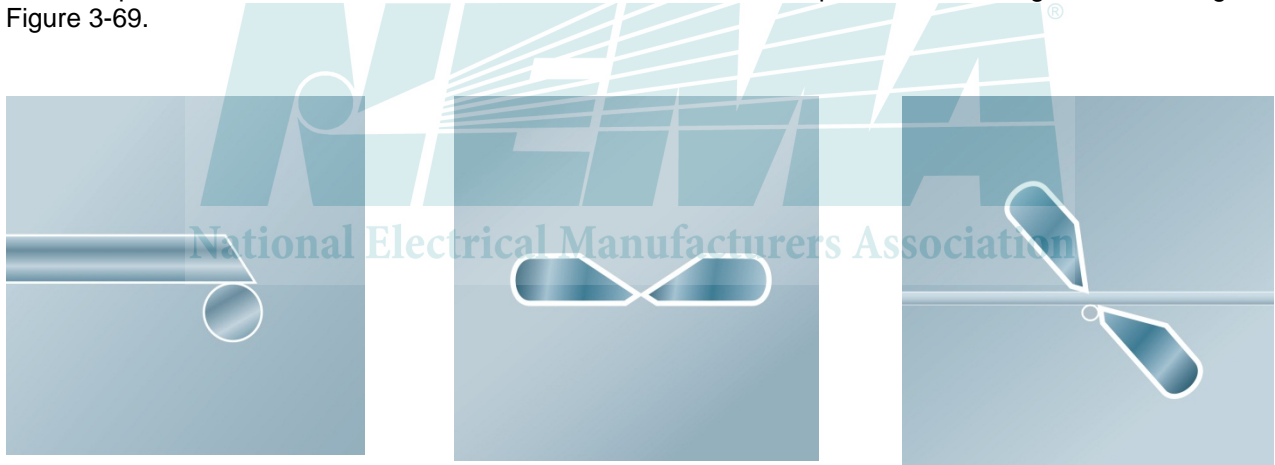

Figure 3-67 Correct Cut

Figure 3-68 Correct Blades to Use to Use

Figure 3-69 Correct Blade Placement

For examples of incorrect cut, incorrect blades to use, and incorrect blade placement, see Figure 3-71 through Figure 3-72.

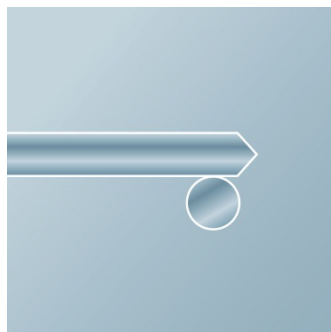

Figure 3-70 Incorrect Cut

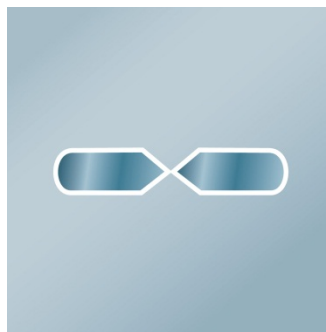

Figure 3-71 Incorrect Blades to Use



Figure 3-72 Incorrect Blade Placement

3.6.3 Drilling

Holes for splice plates must be drilled in field-cut cable trays. The most common method of locating the hole positions is to use a splice plate as a template. Drill jigs (see Figure 3-73) are also available. A short piece of side rail that is punched with the standard factory hole pattern can be bolted to the splice plate to serve as a stop that rests against the end of the field-cut side rail (see Figure 3-74). Clamp the splice plate to the rail, and drill through the splice plate holes and the side rail (see Figure 3-75). The correct drill size depends on the hardware supplied with the cable tray. Match the holes that exist in the cable tray. After drilling, remove burrs.

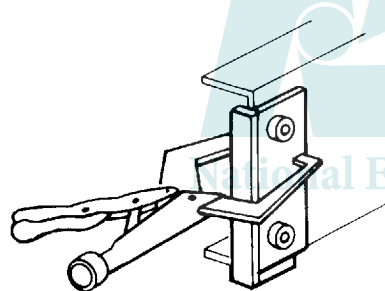

Figure 3-73 Drilling with Drill Jigs

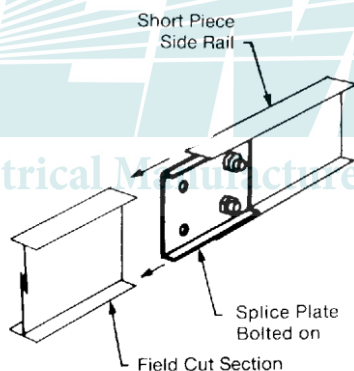

Figure 3-74 Drilling with Punched Side Rail

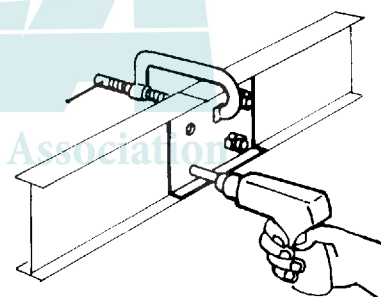

Figure 3-75 Drilling with Clamp and Side Rail

3.6.4 Finish Touch-Up

H.D.G.A.F. cable trays need to be retouched after cutting, drilling, or deburring, or if the coating becomes damaged. These cutting operations leave bare metal edges that will begin to corrode immediately. Cable trays made from mill-galvanized steel do not need to be touched up because they are not designed to be used in heavily corrosive atmospheres and have bare metal edges inherent in their design. Aluminum cable trays do not need to be touched-up.

Touch-up of the galvanized finish must be done according to ASTM A780. Use an approved zinc-rich galvanizing material that meets the requirements of ASTM A780. If it is not noted on the product label as to whether the material meets ASTM A780, the material specification sheet should be obtained from the galvanizing material supplier. The paint can be applied by brushing or spraying. Always paint 13 mm (1/2 in) to 25 mm (1 in) beyond the bare area to prevent undercutting by corrosion.

After cutting or drilling fiberglass cable trays, seal the cut edges with the manufacturer's recommended sealant.

Other protective coatings that are cut or damaged must be touched up with compatible coatings.

3.6.5 Wire Mesh Fittings Fabrication

For examples, see Figure 3-76. Fittings may be field-fabricated from straight sections on-site with an offset bolt cutter and wrench, or a high-speed grinder. Care shall be taken if a wire mesh tray's cross-sectional area changes as a result of field fabrication. All manufacturer instructions, as well as additional requirements for bonding and grounding, shall be followed.

Horizontal or vertical bends, tees, and crosses are fabricated by notching out segments of side rail grids, and overlapping and connecting parallel wires by means of a connector.

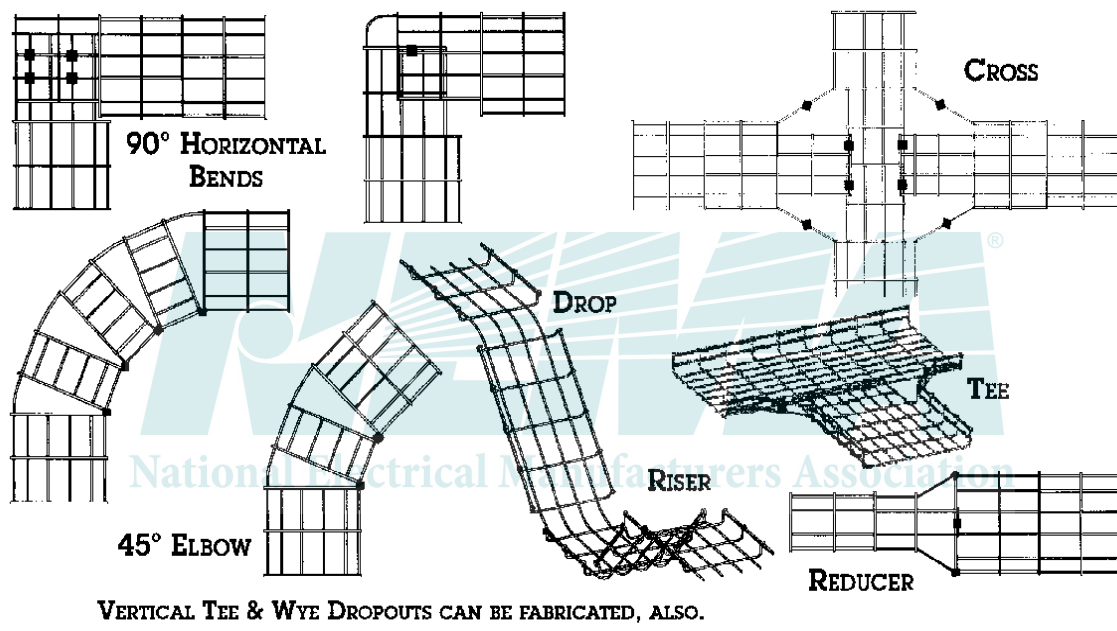
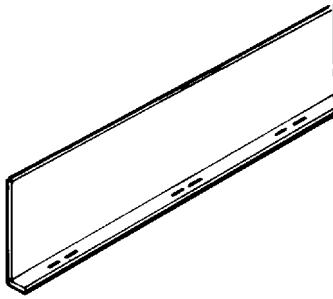

Figure 3-76 Typical Wire Mesh Fittings—Field-Fabricated

3.7 ACCESSORIES

3.7.1 Barrier Strips

For examples, see Figure 3-77 through Figure 3-79.



**Figure 3-77 Barrier Strip—
Straight Section**

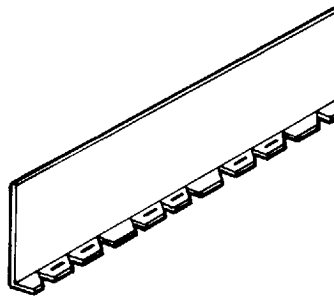

**Figure 3-78 Barrier Strip—
Horizontal Fitting**

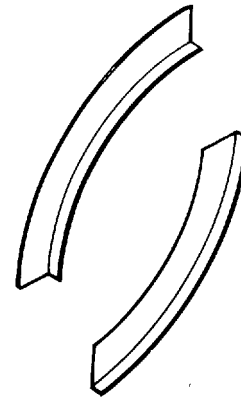

**Figure 3-79 Barrier Strip—
Vertical Fitting**

Barrier strips are sometimes used to separate cables within a cable tray, as required by the NEC. For an example, see Figure 3-80.

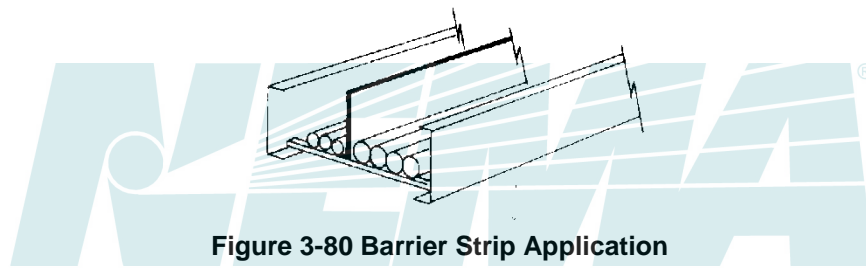
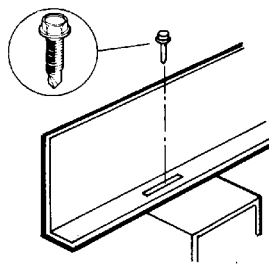

Figure 3-80 Barrier Strip Application

Barrier strips are installed by placing them at the desired location(s), then fastening them down with the hardware provided, or bonding with adhesive (only in the case of fiberglass only). For examples, see Figure 3-81 and Figure 3-82. This connection should be made at approximately every 900 mm (3 ft)



**Figure 3-81 Barrier Strip Attachment—Self-
Drilling and Self-Tapping Screw**

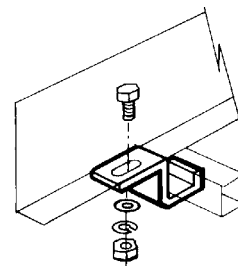

Figure 3-82 Barrier Strip Attachment—Clip

Barrier strips along a cable tray run may be connected using a barrier strip splice. For examples, see Figure 3-83 and Figure 3-84.

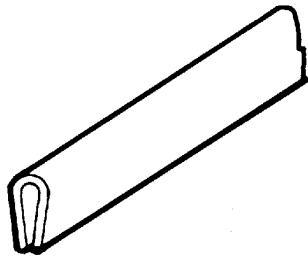

Figure 3-83 Barrier Strip Slice Barrier

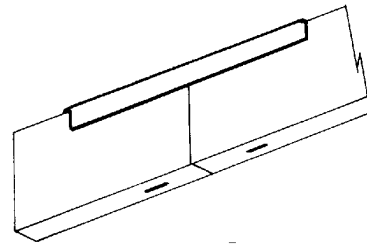

Figure 3-84 Barrier Strip Splice—Installed

3.7.2 Drop-Outs

For examples, see Figure 3-85 through Figure 3-87. The drop-outs and drop-out bushings provide a smooth surface to protect the cable insulation as it exits the cable tray.

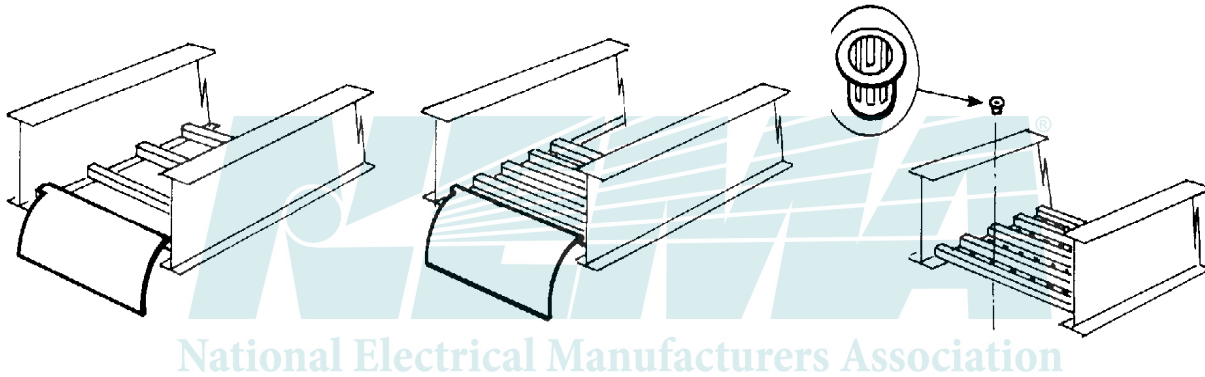

Figure 3-85 Ladder Drop-Out

Figure 3-86 Trough Drop-Out

Figure 3-87 Trough Drop-Out Bushing

3.7.3 Cable Channel to Cable Tray

Attaching a channel cable tray by using the method illustrated in Figure 3-88 maintains the electrical requirements, and the bolted mechanical connection, while providing a practical method for dropping tray cables to equipment. Wire mesh systems also may be a wise consideration for supporting cable drops.

A channel cable tray can be added to an existing cable tray system using the method illustrated in Figure 3-89 to add approved cabling systems. Refer to the loading information of the existing cable tray system to confirm that any additional loading will not surpass the stated loading capacity.

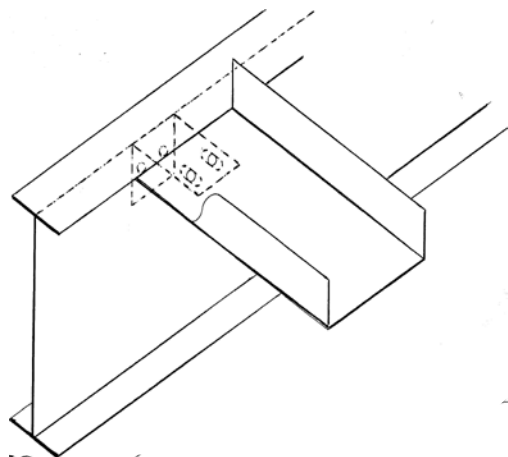

Figure 3-88 Cable Tray to Channel

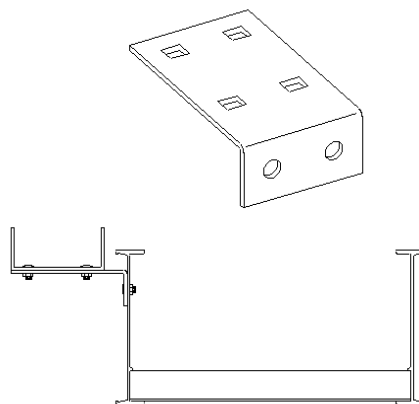

Figure 3-89 Channel to Ladder Tray Bracket

3.7.4 Conduit to Cable Tray Adaptors

For examples, see Figure 3-90 through Figure 3-92. These adaptors provide for attachment of conduit that terminates at a cable tray run. If a connector is not listed, it provides only a mechanical, not an electrical, connection. To make an electrical connection, an equipment grounding conductor must be run from the conduit to the cable tray. When using a conduit system to exit or enter a cable tray system, verify the proper conductor installation. Tray-rated cables are required for cable tray installation, so using a channel cable tray system or wire mesh system for exits may be more convenient and economical.

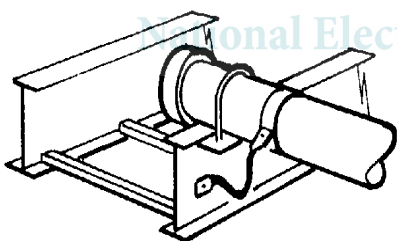

Figure 3-90 Installed
Conduit to Cable Tray
Adapter

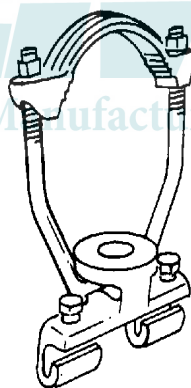

Figure 3-91 Swivel Conduit
to Cable Tray Adapter

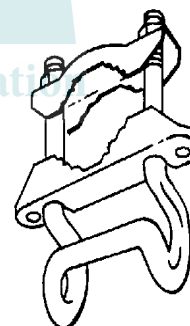

Figure 3-92 Conduit to
Cable Tray Adapter

3.7.5 Covers and Clamps

Examples of cable tray covers are provided in Figure 3-93.

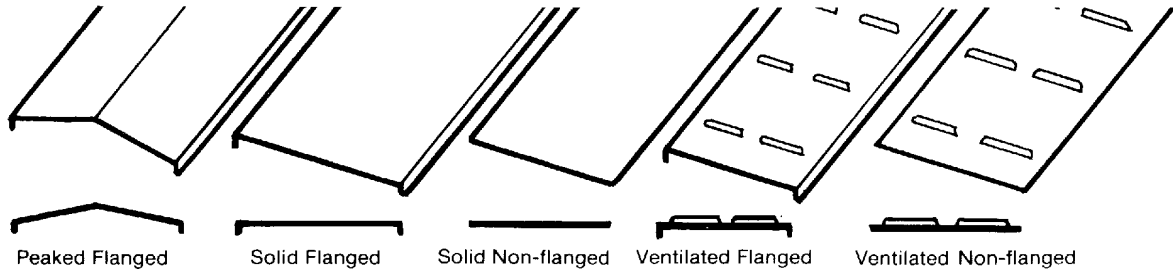

Figure 3-93 Cable Tray Covers

Covers are typically added to a cable tray system when additional cable protection is required. It is important to consider that tray-rated cables have mechanical and UV protection built into their construction, making the sound use of covers uncommon. It is recommended to install covers the first six feet of a cable tray system extending vertically from a floor penetration. If a cable tray system passes under an open walkway, the cables should be protected from possible falling objects in the immediate area. Should a cable tray system temporarily be subjected to falling debris, a temporary cover should be used and then removed when no longer necessary. Cover installation also has merit in certain environmental air handling area installations. Refer to local codes for project requirements.

Adding covers to a cable tray system may limit access, thus affecting the ability to add, mark, or remove cabling in the future. In the case of power cables, the addition of covers may require that the conductors be de-rated and may affect the loading of the cable tray system.

In general, installing covers on outdoor cable tray systems is not common practice. Should covers be required, proper attachment is required to protect them from wind forces.

When specifying covers for a system make sure the material and finish is clearly stated to satisfy the installation need and environment. For examples of cable tray cover clamps and accessories, see Figure 3-94.

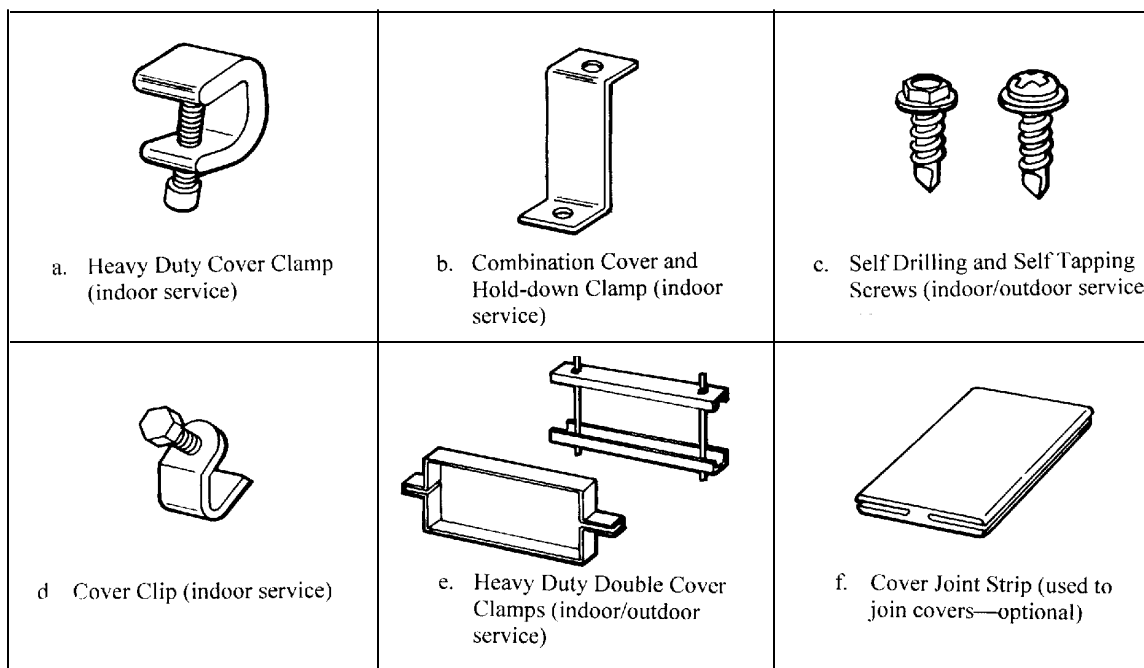

Figure 3-94 Cable Tray Cover Clamps and Accessories

NOTE: Special consideration should be given to wind loading on outdoor applications.

Table 3-3 provides information on the required spacing for cover clamps.

Table 3-3 Quantity of Standard Cover Clamps Required

Straight section, 1.8 m (6 ft)	4 pieces
Straight section, 3.0 m (10 ft) and 3.7 m (12 ft)	6 pieces
Horizontal/vertical bends	4 pieces
Tees	6 pieces
Crosses	8 pieces

NOTE: When using the heavy-duty cover clamp shown in Figure 3-94 e, only half the quantity of pieces are required.

3.8 GROUNDING AND BONDING

NEC Article 392.60 requires that metallic cable trays be grounded and electrically continuous.

In general, non-current-carrying parts of equipment that are likely to become energized are required to be connected to an equipment grounding conductor (EGC). For further information, see NEC Articles 250.96, 250.110, 250.112, and 250.134.

Some manufacturers may recommend bonding and/or grounding of their equipment for other purposes, such as electromagnetic interference (EMI), radio frequency interference (RFI), or electrostatic discharge (ESD).

NOTE: For further information, see NEC Articles 250.20(A), 250.112(I), 800.2, 800.50, and 800.100.

Cable trays are suitable as EGC's when classified to NEMA VE 1.

For specific areas requiring bonding for electrical continuity, refer to Figure 3-95 through Figure 3-98.

3.8.1 Cable Tray Used as an Equipment Ground Conductor (EGC)

For examples, see Figure 3-95 through Figure 3-98. Aluminum and steel cable tray, fittings, and connectors are permitted to be used as an EGC in accordance with NEC Article 392.60 under the conditions specified, if classified and marked with the cross-sectional area. Using Table 3-4, verify that the cross-sectional area of the cable tray, fittings, and connectors are all appropriate for the maximum rating or setting of the overcurrent protection device.

If bonding jumpers are used, or if cable tray connectors are not classified as EGCs, NEC Article 250.102 specifies bonding jumper sizes.

NOTE: Stainless steel cable trays are not permitted for use as an EGC. Stainless steel cable trays or stainless steel splice connectors require proper bonding, using manufacturer-recommended methods, per NEC Articles 392.60 and 250.96.

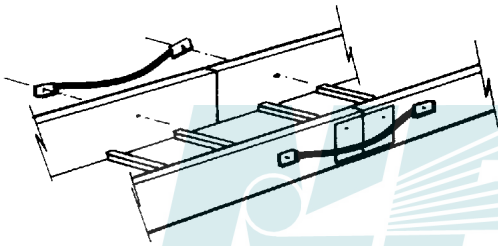

Figure 3-95 Expansion Splice Plates

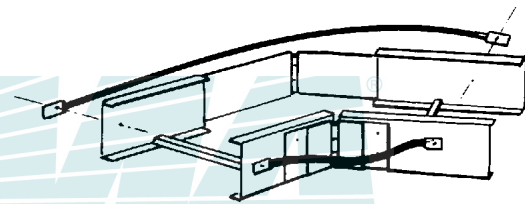

Figure 3-96 Horizontal Adjustable Splice Plates

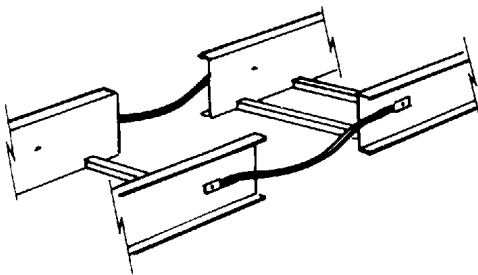

Figure 3-97 Discontinuous

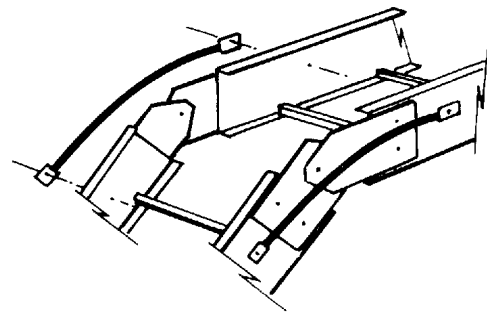

Figure 3-98 Cable Tray Sections Vertical Adjustable Splice Plate

3.8.2 Cable Trays with Wire-Type Equipment Grounding Conductor (EGC) Installed

For an example, see Figure 3-99. When a wire-type EGC is installed in or on cable tray, it may be bonded to the cable tray with a grounding clamp. Grounding clamp styles include bolted lug types, which require drilling the cable tray side rail, and clamp-on styles that work like a beam clamp. One listed grounding

clamp should be used on each section of cable tray. Install a wire-type EGC or bonding jumper at areas where:

- a) the cable tray is not mechanically continuous, or
- b) non-classified connectors are installed, or
- c) gaps surpass the length of traditional bonding jumpers.

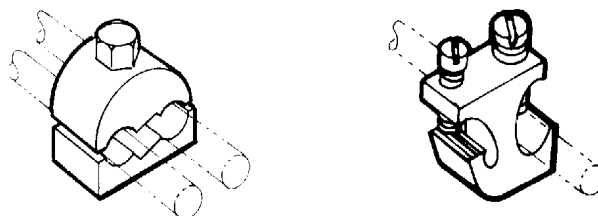

Figure 3-99 Grounding Clamps

Bare copper wire-type EGC should not be used in or on aluminum cable tray. Bonding jumpers are not required if the wire-type EGC is properly bonded to all equipment.

3.8.3 Check for Properly Sized EGC or Bonding Jumpers

3.8.3.1 Power Applications

Bonding jumpers and EGCs are sized according to NEC Articles 250 and 392.

NOTE: NEC Table 392.60(A) is the actual circuit breaker trip setting, and not the maximum allowable, under the conditions in NEC Article 240.6. If the maximum ampere rating of the cable tray system is not sufficient for the protective device used, the cable tray system cannot be used as an EGC, and the NEC requires that a wire-type EGC be included in the cable tray system.

3.8.3.2 Non-Power Applications

Cable tray systems containing conductors outside the scope of NEC Article 250 (such as data, communications, signal cables, or others) still require proper bonding and grounding for system operation and performance.

Metal trays containing these conductors shall be electrically continuous, via listed connectors or the use of a bonding jumper.

Electrical continuity across field-fabricated wire mesh fittings can be accomplished using listed wire mesh tray connectors and following the manufacturer's installation instructions.

3.8.3.3 Mixed Systems

When single-conductor power conductors are installed in metallic cable tray systems with non-power conductors, see the bonding and grounding guidance in Section 3.8.3.1.

NOTE: Power and non-power cables should be separated with a fixed barrier.

Table 3-4 Metal Area Requirements for Cable Tray Systems Used as Equipment Grounding Conductors (NEC Table 392.60(A))

Maximum Fuse Ampere Rating, Circuit Breaker Ampere Trip Setting, or Circuit Breaker Protective Relay Ampere Trip Setting for Ground-Fault Protection of Any Cable Circuit In the Cable Tray System	Minimum Cross-Sectional Area of Metal*			
	Steel Cable Trays		Aluminum Cable Trays	
	mm ²	in ²	mm ²	in ²
60	129	0.20	129	0.20
100	258	0.40	129	0.20
200	451.5	0.70	129	0.20
400	645	1.00	258	0.40
600	967.5	1.50**	258	0.40
1000	--	--	387	0.60
1200	--	--	645	1.00
1600	--	--	967.5	1.50
2000	--	--	1290	2.00**

* Minimum cross-sectional area of metal (as adapted from NEC Table 392.60(A)):

- a) both side rails for ladder or trough cable tray systems; or
- b) in single-rail or channel cable tray systems, or cable tray systems of one-piece construction; or
- c) longitudinal wires for wire mesh cable tray systems.

** NEC Table 392.60(A) states:

“Steel cable trays shall not be used as equipment grounding conductors for circuits with ground-fault protection above 600 amperes. Aluminum cable trays shall not be used as equipment grounding conductors for circuits with ground-fault protection above 2000 amperes.”

NOTE: See Section 4.7.3.1 to select wire-type EGC.

National Electrical Manufacturers Association

Table 3-5 Minimum Size Equipment Grounding Conductors for Grounding Raceway and Equipment (NEC Table 250.122)

Rating or Setting of Automatic Overcurrent Device in Circuit Ahead of Equipment, Conduit, etc., Not Exceeding(Amperes)	Wire Size (AWG or kcmil)	
	Copper	Aluminum or Copper-Clad Aluminum*
15	14 AWG	12 AWG
20	12	10
60	10	8
100	8	6
200	6	4
300	4	2
400	3	1
500	2	1/0
600	1	2/0
800	1/0	3/0
1000	2/0	4/0
1200	3/0	250 kcmil
1600	4/0	350
2000	250 kcmil	400
2500	350	600
3000	400	600
4000	500	750
5000	700	1200
6000	800	1200

* See installation restrictions in NEC Article 250.

3.8.4 How to Install Bonding Jumpers

For examples, see Figure 3-100. Bonding jumper types include insulated, bare, braided, or laminated.

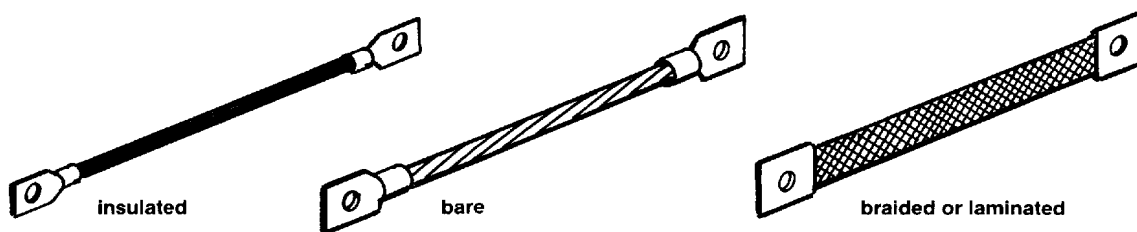

Figure 3-100 Bonding Jumper Examples

Drill holes in each side rail 50 mm (2 in) from each end of the splice plate so the bonding jumper spans the discontinuity. Do not use splice plate bolt locations to connect the bonding jumper to cable tray.

Place the screw head on the inside of cable tray. Put the bonding jumper on the outside of the cable tray, add a flat washer and locknut, and then tighten.

3.9 BONDING TO THE METAL FRAME OF THE BUILDING AND EARTH

Metallic cable trays are permitted to be bonded to the metal frame of the building and earth for signal grounding (“noise” prevention). This may be desirable if the cable tray system is not inherently bonded (connected) to the metal frame of the building and earth through metallic support systems.

Section 4 INSTALLATION OF CABLE

The NEMA 5CT Cable Tray Section acknowledges input provided by NEMA wire and cable manufacturers to Section 5.

4.1 GENERAL

This section offers some general guidelines or rules of thumb on installing cable in cable tray. This information is not intended to replace the recommendations of the cable manufacturer. The manufacturer of the product is the best source for information on the product, its use, and installation practices.

4.2 HANDLING AND STORAGE

To avoid personal injury or damage to the cable and reels, follow the guidelines below for handling and storage of cable upon receipt at the job site:

- a) Inspect all reels upon receipt for proper material and any type of damage. Be sure to note any damage on the receiving papers. Do not allow the reels to drop from the delivery truck during the unloading process. When a forklift is used, the forks need to support both reel flanges. Reels can be hoisted by lifting on a metal shaft, of sufficient size and strength, placed through the reel's center hole. Avoid handling equipment coming in contact with the cable.
- b) Reels may be marked with a directional arrow and a phrase such as "Roll This Way" to indicate the proper direction to roll the reel. Reels should be rolled only in the direction shown, or in the direction opposite to the direction that the cable is wrapped on the reel. Rolling reels in the wrong direction can cause the cable to loosen on the reel, which may cause problems during cable de-reeling or installation. Do not allow reels to roll uncontrolled as they may roll into objects, damaging the cable or causing personal injury. To maintain control when rolling a reel down an incline, the incline should be as gradual as possible.
- c) Use care when choosing a location for cable storage. The temperature of the storage location should be -10°C (14°F) or higher. Select an area that is remote from construction activity, where the cable will be protected from equipment, falling objects, excessive heat, or cold, chemicals, etc., resulting in potential damage. Cable reels should be stored indoors on a dry surface or, if stored outdoors, placed on suitable dunnage of sufficient size to support the reel weight without sinking or allowing the reels to come into contact with moisture. Reels stored outside (prior to and after installation) should be covered with weatherproof material to protect reels and cable from sunlight and moisture, and keep cable ends sealed and fastened to the reel flange to prevent them from laying on the ground. Reels should never be stored or stacked on their sides. Store reels on their flanges, properly chocked to prevent rolling. Be sure to allow enough room between reels to allow access to the reels for removal.

4.3 CABLE TRAY PREPARATION

Before installing cable in the cable tray, examine cable paths to ensure all areas are free of debris that may interfere with cable installation. Cable tray should never be used as a walkway.

4.4 CABLE PULLING CONSIDERATIONS

Most cable installations require the use of cable pulling tools (see Figure 4-1).

- a) On horizontal straight runs, cables generally ride on rollers mounted in or on cable trays (see Figure 4-4). These rollers should be properly spaced, depending on the size and weight of the cable, to prevent the cable from sagging and dragging in the cable tray during the pull. Contact the cable manufacturer for information regarding proper roller spacing.
- b) On horizontal bends and vertical pulls, cables are generally run through pulleys or sheaves to maintain a minimum bending radius (see Figure 4-5 and Figure 4-6). Pulleys and sheaves of

sufficient diameter prevent pinching the cable between the pulley flanges. Maintain each cable's minimum bending radius to prevent damage to the cable. Contact the cable manufacturer for the proper minimum bending radius. Multiple pulling tools may be required at one bend to maintain this radius. Be careful with the entry and exit angle of the cable at the pulling tool, as this angle can exceed the bending radius.

- c) Due to the length of some cable pulls and the cable weight, a great deal of force can be applied to the pulleys on horizontal and vertical bends. These pulleys should be anchored to the structural steel and not to the cable tray due to the force that can be applied during pulling. Do not pull down on the horizontal rollers; they are not designed for this purpose, and damage to the cable or cable tray could result.

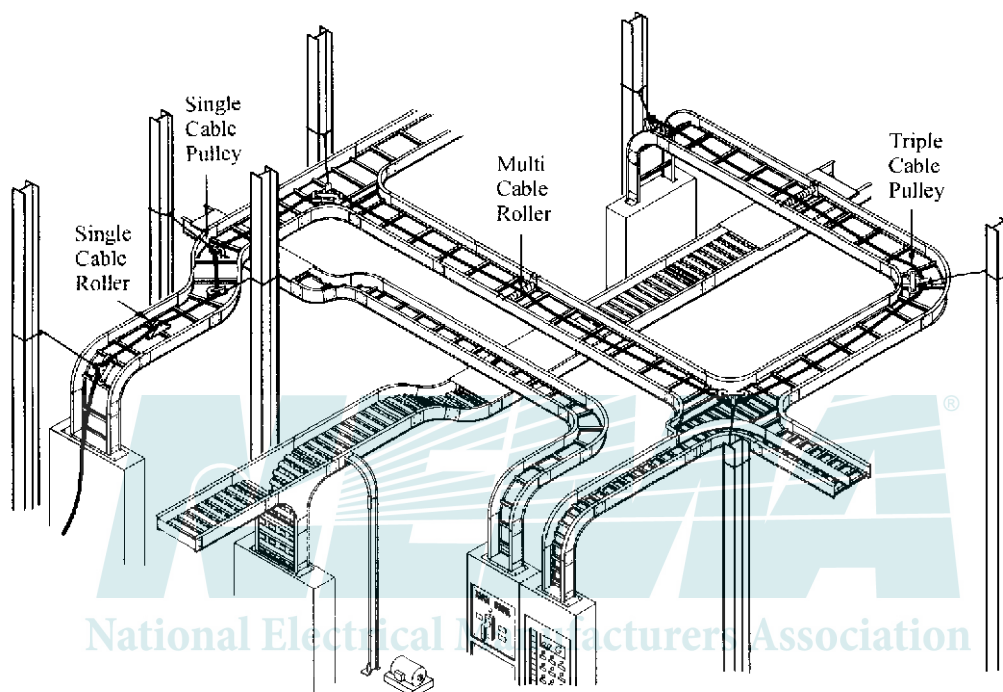

Figure 4-1 Cable Installation

4.5 PULLING THE CABLE

Larger cables usually require a basket grip and/or pulling eye to be attached to the leading end of the cable's metallic conductor(s). If your cable does not have a pulling eye attached by the manufacturer, contact the cable manufacturer for information on field installation of a pulling eye and/or basket grip (see Figure 4-2 and Figure 4-3). Where pulling attachments are used on the conductors, cover them with rubber-like or plastic tapes to prevent scoring of the cable trays and installation sheaves during a conductor pull. Generally, the reel will be placed on reel jacks with an axle of sufficient size and strength to allow the reel to turn freely with minimum friction. Since cables have pulling tension restrictions, a dynamometer may be installed at the pulling end and the readings recorded with every pull to ensure that the cable's maximum pulling tension is not exceeded.

Communications should be established between the pulling end of the run and the reel end of the run. During the pull, the cable should be pulled at a constant speed. Contact the cable manufacturer for maximum pulling tension and cable pulling speed. Be sure to have adequate personnel available at the reel end to aid in feeding the cable, to watch and prevent cables from getting crossed, and for reel braking if necessary. Be sure to pull enough cable to allow for removal of pulling eyes or basket grips and resealing of cable ends and connections. Once the cable is installed, remove the cable from the pulling devices and lay it in the cable tray. Do not allow cables to drop in the cable tray; this may damage the cable and/or the cable tray. If cable connections are not to be made immediately, the pulling eye or

basket grip should be removed and all cable ends resealed to prevent moisture from entering the cable (see Figure 4-4 through Figure 4-6).

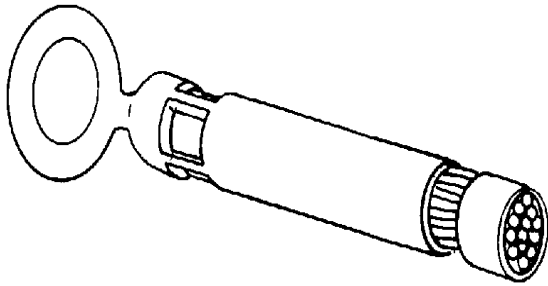

Figure 4-2 Pulling Eye

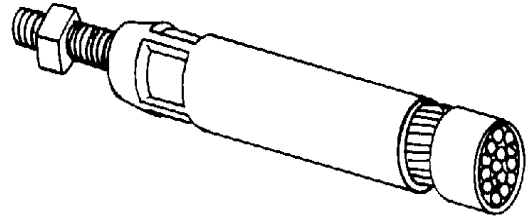

Figure 4-3 Pulling Bolt

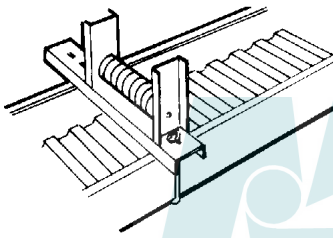

Figure 4-4 Straight Roller
(Top Mounted)

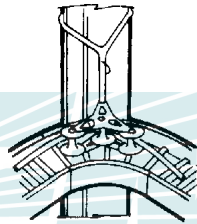

Figure 4-5 Triple Pulley
Guide

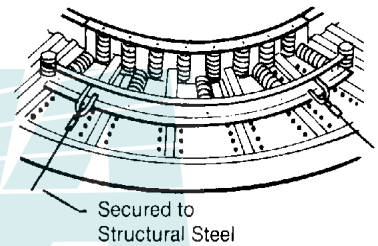

Figure 4-6 90° Roller
Guide

4.6 FASTENING CABLES

- Cables may be fastened to the cable tray by means of cable clamps or cable ties (see Figure 4-7 and Figure 4-8). Generally, cables are fastened every 450 mm (18 in) on vertical runs. Although not required by the NEC, single conductor cables can be fastened on horizontal runs to maintain spacing and ensure that the cable is confined within the cable fill area. When using cable clamps, the clamps should be sized correctly and tightened only enough to secure the cable without indenting the jacket. The same precaution should be observed with cable ties, and they should be applied with a pressure-limiting device.
- Extremely long vertical drops introduce a new set of issues requiring special consideration. The weight per meter (foot) of the cable multiplied by the number of meters (feet) in the vertical drop, in many cases, exceeds the load carrying capacity of the cable tray component. The one or two rungs supporting this weight are likely to be damaged, and the vertical load could exceed the allowable cable tension. The cable weight should be supported in such a manner as to prevent damage to the cable tray or cable during this type of installation. As the cable is installed, intermediate supports should be installed on the vertical drop to break the cable load into segments supported at multiple places.
- Offshore installations may require stainless steel cable ties, or stainless cable banding, depending on the cable positioning.

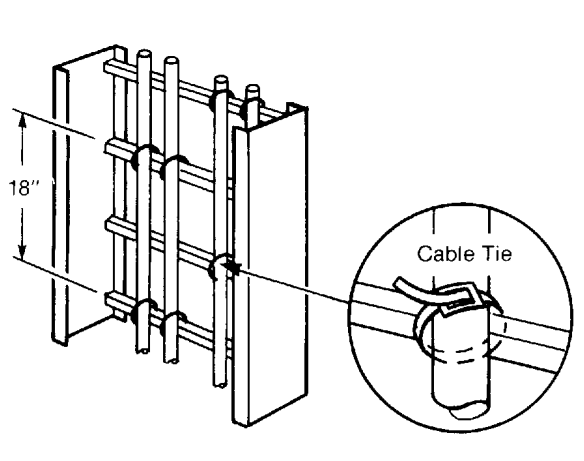

Figure 4-7 Cable Ties—Vertical Application

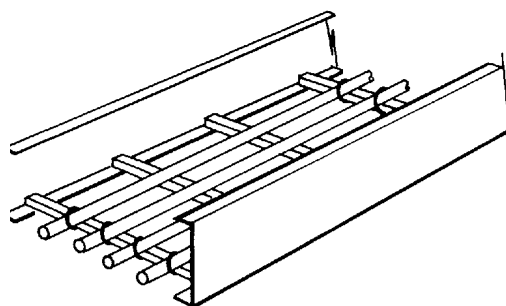

Figure 4-8 Cable Ties—Horizontal Application

4.7 PROTECTING INSTALLED CABLE

Once the cable is installed in an open cable tray system, take care to protect the exposed cables from falling objects or debris that could cause damage to the cable. In areas where the cable tray is to be covered, covers should be installed as soon as possible. Temporary protection for the cables and cable tray can be constructed of available wood or metal materials until the risk of damage has passed.



Section 5 MAINTENANCE

WARNING—No electrical apparatus should be worked on while it is energized. When it is necessary to work in the vicinity of energized cables, all safety precautions should be followed, such as described in NFPA 70E. If cables are to be touched or moved, they should be de-energized.

5.1 INSPECTION

Although cable tray is virtually maintenance free under normal conditions, inspection of cable tray is recommended as part of a facility's routine maintenance schedule for electrical equipment. Cable tray should be inspected and serviced by qualified personnel.

Visual checks should be made for loose bolted connections at joints and bonding areas. Tighten all hardware in suspect areas.

Visual checks should be made for deposits of dust, foreign objects, and debris. These items should be removed to improve ventilation and reduce the potential for fire hazard.

Inspect cable tray after any severe weather, including high winds, seismic disturbances, or other abnormal occurrences.

5.2 INACTIVE OR ABANDONED CABLES

Good cable and wire management includes removing inactive or abandoned cables from the cable tray system. This practice opens capacity in the cable tray system for future cable needs and eliminates the difficulty electricians have in trying to establish the routing of an inactive cable.

5.3 ADDING CABLES

When additional cables are to be added to the cable tray system, refer to NEC Article 392 or CEC Part 1 (for allowable fill) and NEMA VE 1 and NEMA FG 1 (for allowable load). Check the adequacy of supports before installing additional loads.

Follow the cable manufacturer's recommended procedures for pulling and installing cables (also see Section 5).

ANNEX A TYPICAL CABLE TRAY TYPES

Annex A provides examples of typical cable tray types.

A.1 CABLE LADDERS

For examples of cable ladders, see Figure A-1 through Figure A-3.

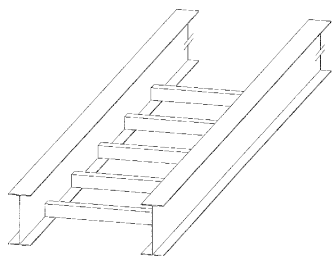

Figure A-1 I-Beam

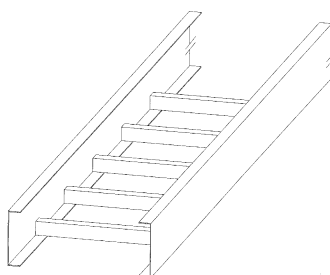

Figure A-2 C-Channel
Flange In

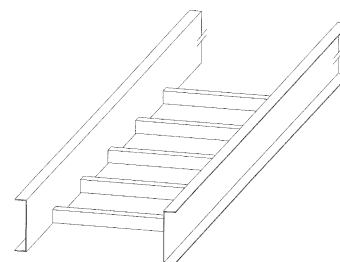

Figure A-3 C-Channel
Flange Out

A.2 SINGLE-RAIL CABLE TRAYS

For examples of single-rail cable trays, see Figure A-4 through Figure A-6.

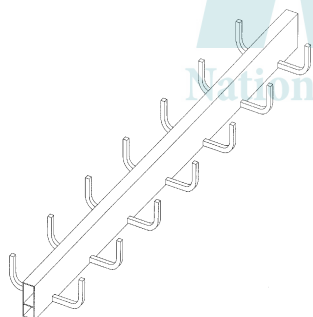

Figure A-4 Center Rail
Cable Tray



Figure A-5 Single-Tier Wall
Mount

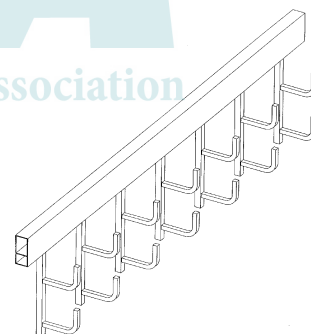

Figure A-6 Multi-Tier Wall
Mount

A.3 SOLID-BOTTOM CABLE TRAYS

For examples of solid-bottom cable trays, see Figure A-7 through Figure A-10.

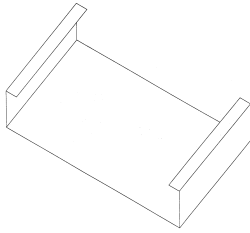

Figure A-7 Pan
Flange In

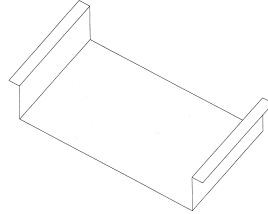

Figure A-8 Pan
Flange Out

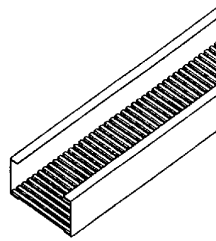

Figure A-9
Corrugated
Bottom

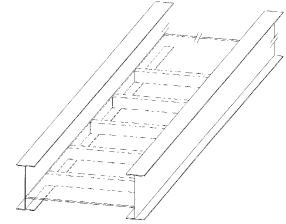

Figure A-10 Solid
Sheet on Top of
Ladder Rung

A.4 TROUGH (VENTILATED CABLE TRAYS)

For examples of trough (ventilated cable trays), see Figure A-11 through Figure A-13.

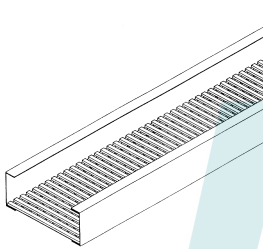

Figure A-11 Corrugated
Bottom with Holes

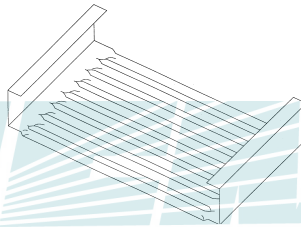

Figure A-12 Pan with
Louvers

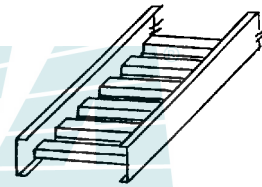

Figure A-13 Tray with Close
Rung Spacing

A.5 WIRE MESH CABLE TRAY

For an example of wire mesh cable tray, see Figure A-14.

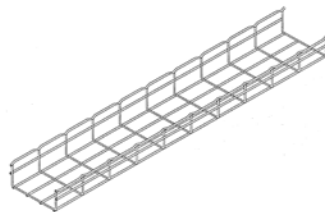

Figure A-14 Wire Mesh

A.6 CHANNEL CABLE TRAYS

For examples of channel cable trays, see Figure A-15 and Figure A-16.

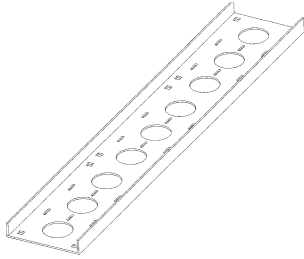

Figure A-15 Ventilated Bottom

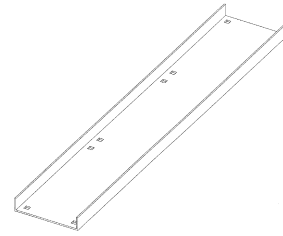

Figure A-16 Solid Bottom

§

