

NEMA Standards Publication TS 2-2003 (R2008)

Traffic Controller Assemblies with NTCIP Requirements (Version 02.06)

Amendment 3-2009

Contactor Amendment

Published by:

National Electrical Manufacturers Association

1300 North 17th Street, Suite 1752

Rosslyn, Virginia 22209

www.nema.org

© Copyright 2012 by the National Electrical Manufacturers Association. All rights including translation into other languages, reserved under the Universal Copyright Convention, the Berne Convention for the Protection of Literary and Artistic Works, and the International and Pan American Copyright Conventions.

NOTICE AND DISCLAIMER

The information in this publication was considered technically sound by the consensus of persons engaged in the development and approval of the document at the time it was developed. Consensus does not necessarily mean that there is unanimous agreement among every person participating in the development of this document.

The National Electrical Manufacturers Association (NEMA) standards and guideline publications, of which the document contained herein is one, are developed through a voluntary consensus standards development process. This process brings together volunteers and/or seeks out the views of persons who have an interest in the topic covered by this publication. While NEMA administers the process and establishes rules to promote fairness in the development of consensus, it does not write the document and it does not independently test, evaluate, or verify the accuracy or completeness of any information or the soundness of any judgments contained in its standards and guideline publications.

NEMA disclaims liability for any personal injury, property, or other damages of any nature whatsoever, whether special, indirect, consequential, or compensatory, directly or indirectly resulting from the publication, use of, application, or reliance on this document. NEMA disclaims and makes no guaranty or warranty, express or implied, as to the accuracy or completeness of any information published herein, and disclaims and makes no warranty that the information in this document will fulfill any of your particular purposes or needs. NEMA does not undertake to guarantee the performance of any individual manufacturer or seller's products or services by virtue of this standard or guide.

In publishing and making this document available, NEMA is not undertaking to render professional or other services for or on behalf of any person or entity, nor is NEMA undertaking to perform any duty owed by any person or entity to someone else. Anyone using this document should rely on his or her own independent judgment or, as appropriate, seek the advice of a competent professional in determining the exercise of reasonable care in any given circumstances. Information and other standards on the topic covered by this publication may be available from other sources, which the user may wish to consult for additional views or information not covered by this publication.

NEMA has no power, nor does it undertake to police or enforce compliance with the contents of this document. NEMA does not certify, test, or inspect products, designs, or installations for safety or health purposes. Any certification or other statement of compliance with any health or safety-related information in this document shall not be attributable to NEMA and is solely the responsibility of the certifier or maker of the statement.

CONTENTS

	Page
FOREWORD	II
SECTION 1 REPLACE FIGURE 5-4	1
1.1 Delete Existing Figure 5-4 Cabinet Power Distribution Schematic	1
1.2 Insert Replacement Figure 5-4 Cabinet Power Distribution Schematic [Amendment 3].....	2
SECTION 2 REPLACE SECTION 5.4.2.3	3
2.1 Delete Existing Section 5.4.2.3 Signal Bus	3
2.2 Insert Replacement Section 5.4.2.3 Signal Bus [Amendment 3]	4
2.3 Insert NEW Section 5.4.2.3.1 Load Switch DC Power [Amendment 3] [NORMATIVE].....	4

FIGURES

	Page
Figure 5–4 CABINET POWER DISTRIBUTION SCHEMATIC	1
Figure 5–4 CABINET POWER DISTRIBUTION SCHEMATIC [Amendment 3]	2

FOREWORD

This NEMA Standards Publication TS 2-2003, Traffic Controller Assemblies with NTCIP Requirements, has been developed as a design guide for traffic signaling equipment which can be safely installed and provide operational features not covered by the NEMA TS 1-1989, Traffic Control Systems. Within the standard, any reference to a specific manufacturer is made strictly for the purpose of defining interchangeability where there exists no nationally recognized standard covering all the requirements. The manufacturer references do not constitute a preference.

The TS 2 Standards Publication has been established to reduce hazards to persons and property when traffic signaling equipment is properly selected and installed in conformance with the requirements herein. The user's attention is called to the possibility that compliance with this standard may require use of an invention covered by patent rights. By publication of this standard, no position is taken with respect to the validity of this claim or of any patent rights in connection therewith.

Comments and suggestions for the improvement of this document are encouraged. They should be sent to:

Senior Technical Director, Operations
National Electrical Manufacturers Association
1300 North 17th Street
Rosslyn, Virginia 22209

NEMA TS 2-2003 (R2008) Amendment 3 revises NEMA TS 2-2003 (R2008) in two places:

- a) Figure 5-4 Cabinet Power Distribution Schematic (a replacement Figure 5-4 is provided); and
- b) Section 5.4.2.3, Signal Bus (a replacement Section 5.4.2.3 is provided, and a new Section 5.4.2.3.1, Load Switch DC Power, is added).

Section 1 REPLACE FIGURE 5-4

1.1 Delete Existing Figure 5-4 Cabinet Power Distribution Schematic

On page 172 of NEMA TS 2-2003 (R2008), delete existing Figure 5-4, Cabinet Power Distribution Schematic, as follows:

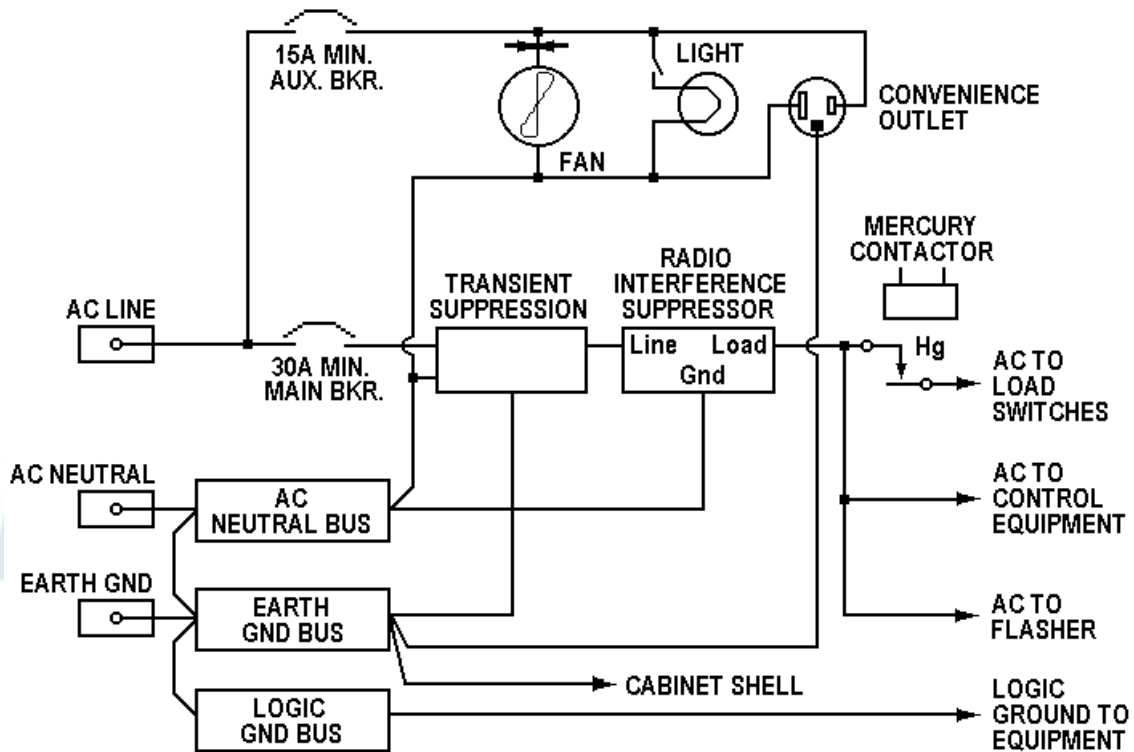

Figure 5-4
CABINET POWER DISTRIBUTION SCHEMATIC

Note: See Section 1.2 for replacement Figure 5-4, Cabinet Power Distribution Schematic [Amendment 3].

1.2 Insert Replacement Figure 5-4 Cabinet Power Distribution Schematic [Amendment 3]

On page 172 of NEMA TS 2-2003 (R2008), insert replacement Figure 5-4, Cabinet Power Distribution Schematic [Amendment 3], as follows:

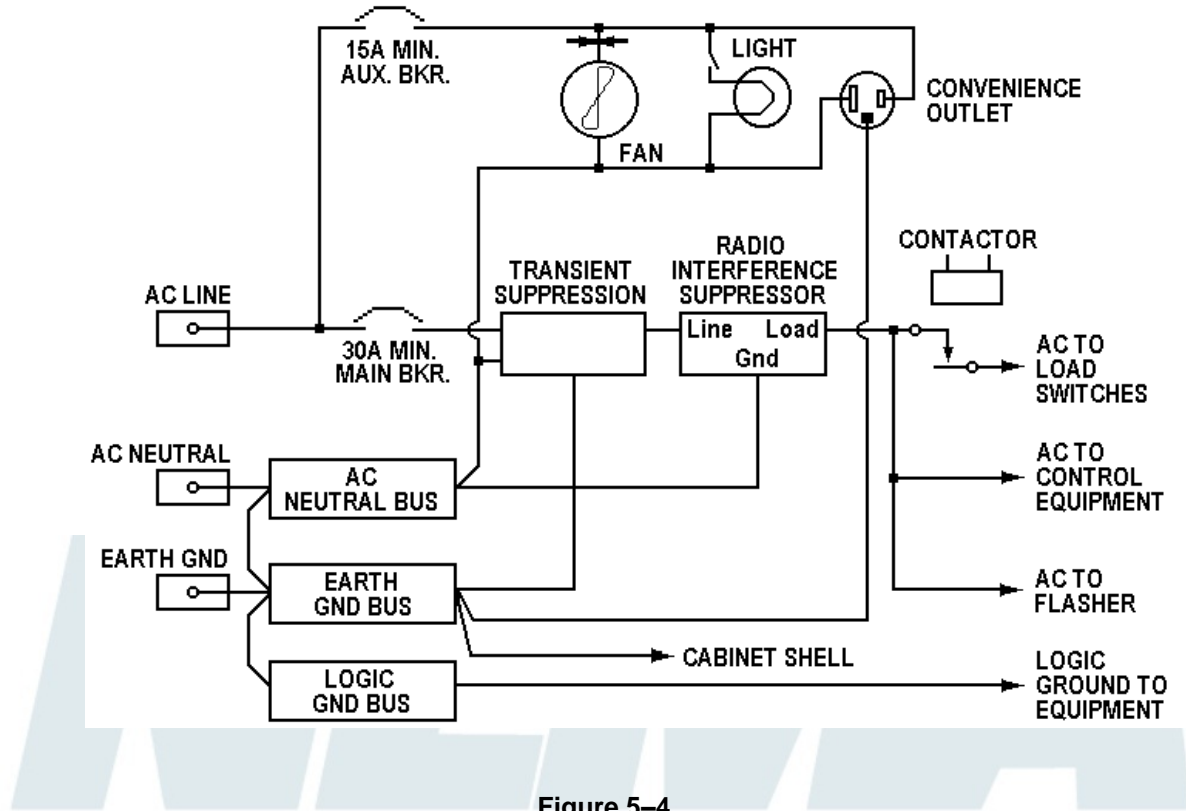

Figure 5-4
CABINET POWER DISTRIBUTION SCHEMATIC [Amendment 3]

Section 2 REPLACE SECTION 5.4.2.3

2.1 Delete Existing Section 5.4.2.3 Signal Bus

On page 173 of NEMA TS 2-2003 (R2008), delete existing Section 5.4.2.3, Signal Bus, as follows:

5.4.2.3 Signal Bus

The signal bus shall be connected to the incoming **AC Line** through a signal bus mercury contactor and a overcurrent protection device. The signal bus mercury contactor shall be energized to provide power to the signal bus. The current rating of the signal bus mercury contactor shall be at least the current rating of the main overcurrent protection device.

Note: See Section 2.2 for replacement Section 5.4.2.3, Signal Bus [Amendment 3], and Section 2.3 for new Section 5.4.2.3.1, Load Switch DC Power [Amendment 3].



2.2 Insert Replacement Section 5.4.2.3 Signal Bus [Amendment 3]

On page 173 of NEMA TS 2-2003 (R2008), insert Section 5.4.2.3, Signal Bus [Amendment 3], as follows:

5.4.2.3 Signal Bus [Amendment 3]

The signal bus shall be connected to the incoming **AC Line** through a signal bus contactor and an overcurrent protection device. The signal bus contactor shall be energized to provide power to the signal bus. The current rating of the signal bus contactor shall be at least the current rating of the main overcurrent protection device.

The purpose of the signal bus contactor is to remove the AC Power from the load switch outputs when the cabinet is in flash transfer operation (MMU Output relay in the Fault state). This is intended to prevent signals that are not routed through the flash transfer relays from being displayed. If the signal bus contactor has failed in the closed state, the AC Power remains connected to the load switch outputs, and incorrect signaling may be visible to the field during flashing operation. [Authorized Engineering Information]

The signal bus contactor should have very high reliability. In addition, the signal bus contactor should have a tendency to fail in the *open* mode, i.e., not passing current. A suitable contactor device should also be rated for continuous duty and should not be affected by transients normally present on the power service. Signal bus contactor contacts should be selected such that welding or shorting of the contacts or otherwise causing the output to fail in the closed condition is minimized. [Authorized Engineering Information]

2.3 Insert NEW Section 5.4.2.3.1 Load Switch DC Power [Amendment 3] [NORMATIVE]

In addition, on page 173 of NEMA TS 2-2003 (R2008), insert a new Section 5.4.2.3.1, Load Switch DC Power [Amendment 3], as follows:

5.4.2.3.1 Load Switch DC Power [Amendment 3]

The cabinet shall be wired such that in the event of a flash transfer operation (MMU Output relay in the Fault state), the 24 VDC power supplied to all load switches shall be removed such that the control circuits cannot activate the load switch circuits. A means shall be provided to manually override the operation of this circuit for diagnostic purposes.

§