

# **NEMA RV 3**

## **APPLICATION AND INSTALLATION GUIDELINES FOR FLEXIBLE AND LIQUIDTIGHT FLEXIBLE METAL CONDUITS**



**NEMA RV 3-2006**

*Application and Installation Guidelines for Flexible and  
Liquidtight Flexible Metal Conduits*

*Published by:*

**National Electrical Manufacturers Association**

1300 North 17th Street, Suite 1752  
Rosslyn, VA 22209

[www.nema.org](http://www.nema.org)

© Copyright 2006 by the National Electrical Manufacturers Association. All rights including translation into other languages, reserved under the Universal Copyright Convention, the Berne Convention for the Protection of Literary and Artistic Works, and the International and Pan American Copyright Conventions.

## NOTICE AND DISCLAIMER

The information in this publication was considered technically sound by the consensus of persons engaged in the development and approval of the document at the time it was developed. Consensus does not necessarily mean that there is unanimous agreement among every person participating in the development of this document.

The National Electrical Manufacturers Association (NEMA) standards and guideline publications, of which the document contained herein is one, are developed through a voluntary consensus standards development process. This process brings together volunteers and/or seeks out the views of persons who have an interest in the topic covered by this publication. While NEMA administers the process and establishes rules to promote fairness in the development of consensus, it does not write the document and it does not independently test, evaluate, or verify the accuracy or completeness of any information or the soundness of any judgments contained in its standards and guideline publications.

NEMA disclaims liability for any personal injury, property, or other damages of any nature whatsoever, whether special, indirect, consequential, or compensatory, directly or indirectly resulting from the publication, use of, application, or reliance on this document. NEMA disclaims and makes no guaranty or warranty, express or implied, as to the accuracy or completeness of any information published herein, and disclaims and makes no warranty that the information in this document will fulfill any of your particular purposes or needs. NEMA does not undertake to guarantee the performance of any individual manufacturer or seller's products or services by virtue of this standard or guide.

In publishing and making this document available, NEMA is not undertaking to render professional or other services for or on behalf of any person or entity, nor is NEMA undertaking to perform any duty owed by any person or entity to someone else. Anyone using this document should rely on his or her own independent judgment or, as appropriate, seek the advice of a competent professional in determining the exercise of reasonable care in any given circumstances. Information and other standards on the topic covered by this publication may be available from other sources, which the user may wish to consult for additional views or information not covered by this publication.

NEMA has no power, nor does it undertake to police or enforce compliance with the contents of this document. NEMA does not certify, test, or inspect products, designs, or installations for safety or health purposes. Any certification or other statement of compliance with any health or safety-related information in this document shall not be attributable to NEMA and is solely the responsibility of the certifier or maker of the statement.

## CONTENTS

		Page
	Foreword.....	iii
<b>Section 1</b>	<b>APPLICATION GUIDELINES FOR FLEXIBLE METAL CONDUIT</b>	
1.1	Construction.....	1
	1.1.1 General.....	1
	1.1.2 Conduit.....	1
1.2	Grounding and Bonding.....	1
1.3	Equipment Grounding Conductor.....	1
1.4	Codes and Standards.....	1
	1.4.1 <i>National Electrical Code</i> <sup>®</sup> .....	1
	1.4.2 Related <i>NEC</i> <sup>®</sup> Articles.....	2
	1.4.3 Underwriters Laboratories (UL) Standards and Directories.....	4
<b>Section 2</b>	<b>APPLICATION GUIDELINES FOR LIQUIDTIGHT FLEXIBLE METAL CONDUIT</b>	
2.1	Construction.....	7
	2.1.1 General.....	7
	2.1.2 Conduit Core.....	7
	2.1.3 Jacket.....	7
	2.1.4 Fittings.....	7
2.2	Grounding.....	7
2.3	Marking.....	7
2.4	Codes and Standards.....	7
	2.4.1 <i>National Electrical Code</i> <sup>®</sup> .....	7
	2.4.2 Related <i>NEC</i> <sup>®</sup> Articles.....	8
	2.4.3 UL Standards and Directories.....	10
<b>Section 3</b>	<b>INSTALLATION GUIDELINES FOR FLEXIBLE METAL CONDUIT</b>	
3.1	Installation Considerations.....	13
	3.1.1 General.....	13
	3.1.2 Special Considerations for LFMC.....	13
	3.1.3 Overall Length of Conduit.....	13
3.2	Securing and Supporting FMC and LFMC.....	14
	3.2.1 Supporting.....	15
	3.2.2 Unsupported.....	15
3.3	Terminating Flexible Metal Conduit.....	15
	3.3.1 Fitting Selection.....	15
	3.3.2 Conduit Preparation and Assembly.....	15
	3.3.3 Cutting Conduit.....	16
	3.3.4 Inserting Conduit.....	16
	3.3.5 Seating a Securement Clamp.....	16
	3.3.6 Tightening Torque.....	17
	3.3.7 Attachment to Unthreaded Entries.....	17
	3.3.8 Attachment to Threaded Entries.....	18
	3.3.9 Terminating Liquidtight Flexible Metal Conduit.....	18

3.4 Verification of Installation..... 20

**Annexes**

Annex A NEMA Engineering Bulletin 93: Restrictions on Installed Lengths of Flexible and Liquidtight Flexible Metal Conduit..... 28

**Tables**

Table 1 Standard Assembly Torque Values for Type FMC Fittings ..... 17  
Table 2 Standard Assembly Torque Values for Type LFMC Fittings ..... 19  
Table 3 Overall Conduit Length for Given Offset & Lateral Distance (1/2)..... 21  
Table 4 Overall Conduit Length for Given Offset & Lateral Distance (3/4)..... 21  
Table 5 Overall Conduit Length for Given Offset & Lateral Distance (1)..... 22  
Table 6 Overall Conduit Length for Given Offset & Lateral Distance (1-1/4)..... 22  
Table 7 Overall Conduit Length for Given Offset & Lateral Distance (1-1/2)..... 23  
Table 8 Overall Conduit Length for Given Offset & Lateral Distance (2)..... 23

**Figures**

Figure 1 Determination of Overall Length of Conduit Installed in a Traveling Vertical Loop with Offset ..... 13  
Figure 2 Tangent Length..... 14  
Figure 3 Flexible Metal Conduit Securement Clamp ..... 24  
Figure 4 Typical Designs of FMC FITTINGS, Clamp Type ..... 25  
Figure 5 Typical Designs of FMC Fittings, Direct-Bearing Screw Type ..... 26  
Figure 6 Typical Designs of FMC Fittings, Screw-In Type ..... 26  
Figure 7 Typical Designs of Liquidtight Flexible Metal Conduit Fittings..... 27

## Foreword

These application and installation guidelines offer practical information on correct usage and industry recommended practices for the installation of Flexible Metal Conduit (Type FMC) and Liquidtight Flexible Metal Conduit (Type LFMC) in accordance with the *National Electrical Code*<sup>®</sup> (*NEC*<sup>®</sup>).

These guidelines have been developed by the NEMA Building Wire and Cable Section's Flexible Metal Conduit Voting Classification, which has committed to periodically reviewing them for any revisions necessary to address changing conditions, product listing and installation requirements, and technical progress. Comments for proposed revisions are welcomed and should be submitted to:

Vice President, Technical Services  
National Electrical Manufacturers Association  
1300 North 17th Street, Suite 1752  
Rosslyn, VA 22209

At the time of approval, the Flexible Metal Conduit Voting Classification of the National Electrical Manufacturers Association had the following members:

AFC Cable Systems—New Bedford, MA  
Alflex Corporation—Long Beach, CA  
Anamet Electrical, Inc.—Mattoon, IL  
Electri-flex Company—Roselle, IL  
International Metal Hose Company—Bellevue, OH  
Southwire Company—Carrollton, GA

< This page is intentionally left blank. >

## Section 1 APPLICATION GUIDELINES FOR FLEXIBLE METAL CONDUIT

### 1.1 CONSTRUCTION

#### 1.1.1 General

Flexible Metal Conduit (Type FMC) is constructed in accordance with the *National Electrical Code*<sup>®</sup> (*NEC*<sup>®</sup>) and complies with the safety requirements of Underwriters Laboratories (UL) *Standard for Safety for Flexible Metal Conduit*, UL 1.

*National Electrical Code*<sup>®</sup> and *NEC*<sup>®</sup> are registered trademarks of the National Fire Protection Association, Inc., Quincy, MA 02269.

#### 1.1.2 Conduit

Flexible Metal Conduit (Type FMC) is constructed with an interlocked corrosion-resistant steel or aluminum strip and is manufactured in accordance with UL 1, which specifies strip thickness, splices, convolutions, interior surfaces, conduit diameters (internal and external) and the quality requirements of aluminum strip and zinc coated steel.

### 1.2 GROUNDING AND BONDING

FMC is approved for bonding when installed in accordance with Articles 348 and 250 of the *NEC*<sup>®</sup>, but limited to 6-foot lengths when used for this purpose.

### 1.3 EQUIPMENT GROUNDING CONDUCTOR

One or more equipment grounding conductors are allowed but are not required. However *NEC*<sup>®</sup> Section 348.60 states that an equipment grounding conductor is required when FMC is used to connect equipment where flexibility is required.

### 1.4 CODES AND STANDARDS

#### 1.4.1 *National Electrical Code*<sup>®</sup>

Flexible Metal Conduit, Type FMC is designed, manufactured and tested for use in accordance with the *National Electrical Code*<sup>®</sup>, Article 348, and with UL 1.

##### 1.4.1.1 Uses Permitted

*NEC*<sup>®</sup> Section 348.10 specifies the permitted uses of FMC as follows:

“FMC shall be permitted to be used in exposed and concealed locations.”

These permitted uses are not all-inclusive, but only provide guidance on where FMC may be used.

In addition to permitted uses covered in Section 348.10, FMC is permitted for installation as follows:

- Outside Branch Circuits and Feeders;
- Services;
- Ducts or plenums used for environmental air;
- In other spaces used for environmental air;
- Under raised floors of computer rooms;
- Lighting whips; and
- Motor leads.

These permitted uses could imply that there is no limitation on the use of FMC. However, limitations are covered in NEC<sup>®</sup> Section 348.12, Uses Not Permitted. Additionally a key provision of the NEC<sup>®</sup> for permitted uses is that wiring methods are required to comply with all applicable Sections of the NEC<sup>®</sup>. For example Article 348 does not impose a length limitation on FMC trade sizes ½ and larger, however when used in accordance with section 430.223 for motor circuits over 600 V, a 6-foot limitation is imposed.

#### 1.4.1.2 Uses Not Permitted

As with permitted uses, those uses not permitted by the NEC<sup>®</sup> are not all-inclusive. The Code language is intended to provide guidance on where and how FMC may be used. NEC<sup>®</sup> Section 348.12 specifies the uses of FMC that are not permitted, which are as follows:

- (1) In wet locations unless the conductors are approved for the specific conditions and the installation is such that liquid is not likely to enter raceways or enclosures to which the conduit is connected
- (2) In hoistways, other than as permitted in 620.21(A)(1)
- (3) In storage battery rooms
- (4) In any hazardous (classified) location other than as permitted in 501.10(B) and 504.20
- (5) Where exposed to materials having a deteriorating effect on the installed conductors, such as oil or gasoline
- (6) Underground or embedded in poured concrete or aggregate
- (7) Where subject to physical damage

The following provides additional guidance on the uses of FMC:

#### Corrosive environments and use underground

Review of the uses not permitted shows that FMC cannot be installed where corrosive environments may be present or in concrete or underground locations. For such installations a Flexible Metal Conduit with a protective outer covering such as Liquidtight Flexible Metal Conduit with an outer nonmetallic jacket approved for the use should be used.

#### Where subject to physical damage

FMC must be protected from physical damage. This includes installing FMC at heights and locations where it will not be exposed to damage. It also includes providing mechanical protection such as from nails and screws in accordance with section 300.4(D) by maintaining a 1-1/4 in. (32 mm) distance from the edge of a framing member or by providing a metal plate where the distance cannot be maintained from the edge of a framing member or a furring strip.

#### 1.4.2 Related NEC<sup>®</sup> Articles

The following NEC<sup>®</sup> Articles also contain provisions for the use of FMC:

##### Wiring and Protection

- ARTICLE 225 Outside Branch Circuits and Feeders  
225.10 Wiring on Buildings
- ARTICLE 230 Services  
230.43 Wiring Methods for 600 Volts, Nominal, or Less
- ARTICLE 250 Grounding and Bonding  
250.118 (5) Use of the Armor of FMC as Equipment Grounding Conductor

Reprinted with permission from NFPA 70-2005, the *National Electrical Code*<sup>®</sup>, © Copyright 2004, National Fire Protection Association, Quincy, MA 02169. This reprinted material is not the official position of the NFPA on the referenced subject, which is represented only by the standard in its entirety.

#### Wiring Methods and Materials

- ARTICLE 300 Wiring Methods
  - 300.22 Wiring in Ducts, Plenums, and Other Air-Handling Spaces
    - (B) Ducts or Plenums Used for Environmental Air
    - (C) Other Space Used for Environmental Air
- ARTICLE 348 Flexible Metal Conduit: Type FMC
- ARTICLE 368 Busways
  - 368.56 Branches from Busways
- ARTICLE 374 Cellular Metal Floor Raceways
  - 374.11 Connection to Cabinets and Extensions from Cells
- ARTICLE 392 Cable Trays
  - 392.3 Uses Permitted (A) Wiring Methods

#### Equipment for General Use

- ARTICLE 410 Luminaires (Lighting Fixtures), Lampholders, and Lamps
  - XIII. Special Provisions for Electric-Discharge Lighting Systems of 1000 Volts or Less
    - C) Wired Luminaire (Fixture) Sections
- ARTICLE 430 Motors, Motor Circuits, and Controllers
  - XI. Over 600 Volts, Nominal
    - 430.223 Conductor Enclosures Adjacent to Motors
  - XIII. Grounding — All Voltages
    - 430.245 Method of Grounding
      - (B) Separation of Junction Box from Motor

#### Special Occupancies

- ARTICLE 501 Class I Locations
  - 501.10 Wiring Methods
    - (B) Class I, Division 2 - (2) Flexible Connections
  - 501.30 Grounding and Bonding, Class I, Divisions 1 and 2
    - (B) Types of Grounding Conductors
- ARTICLE 505 Class I, Zone 0, 1, and 2 Locations
  - 505.15 Wiring Methods
    - (C) Class I, Zone 2 - (2) Flexible Connections
  - 505.25 Grounding and Bonding
    - (B) Types of Equipment Grounding Conductors
- ARTICLE 511 Commercial Garages, Repair and Storage
  - 511.7 Wiring and Equipment Installed Above Class I Locations
    - (A) Wiring in Spaces Above Class I Locations
      - (1) Fixed Wiring Above Class I Locations
- ARTICLE 520 Theaters, Audience Areas of Motion Picture and Television Studios, Performance Areas, and Similar Locations
  - III. Fixed Stage Equipment Other Than Switchboards
    - 520.43 Footlights
      - (B) Other Than-Metal Trough Construction
- ARTICLE 550 Mobile Homes, Manufactured Homes, and Mobile Home Parks
  - II. Mobile and Manufactured Homes
    - 550.15 Wiring Methods and Materials
      - (E) Installation Requirements
    - 550.16 Grounding
      - (2) Connections of Ranges and Clothes Dryers

Reprinted with permission from NFPA 70-2005, the *National Electrical Code*<sup>®</sup>, © Copyright 2004, National Fire Protection Association, Quincy, MA 02169. This reprinted material is not the official position of the NFPA on the referenced subject, which is represented only by the standard in its entirety.

- ARTICLE 551 Recreational Vehicles and Recreational Vehicle Parks
  - IV. Nominal 120-Volt or 120/240-Volt Systems
  - 551.47 Wiring Methods
- ARTICLE 552 Park Trailers
  - IV. Nominal 120-Volt or 120/240-Volt Systems
  - 552.48 Wiring Methods
    - (A) Wiring Systems
- ARTICLE 600 Electric Signs and Outline Lighting
  - II. Field-Installed Skeleton Tubing
  - 600.31 Neon Secondary-Circuit Conductors, 1000 Volts or Less, Nominal
    - (A) Wiring Method
  - 600.32 Neon Secondary Circuit Conductors, Over 1000 Volts, Nominal
    - (A) Wiring Methods
    - (1) Installation
- ARTICLE 604 Manufactured Wiring Systems
  - 604.6 Construction
    - (A) Cable or Conduit Types
    - (2) Conduits
- ARTICLE 610 Cranes and Hoists
  - II. Wiring
  - 610.11 Wiring Method
    - (C) Flexible Connections to Motors and Similar Equipment
- ARTICLE 620 Elevators, Dumbwaiters, Escalators, Moving Walks, Wheelchair Lifts, and Stairway Chair Lifts
  - III. Wiring
  - 620.21 Wiring Methods
- ARTICLE 645 Information Technology Equipment
  - 645.5 Supply Circuits and Interconnecting Cables
    - (D) (2) Under Raised Floors
- ARTICLE 680 Swimming Pools, Fountains, and Similar Installations
  - 680.25 Feeders
    - (A) Wiring Methods

Reprinted with permission from NFPA 70-2005, the *National Electrical Code*<sup>®</sup>, © Copyright 2004, National Fire Protection Association, Quincy, MA 02169. This reprinted material is not the official position of the NFPA on the referenced subject, which is represented only by the standard in its entirety.

### **1.4.3 Underwriters Laboratories (UL) Standards and Directories**

UL publishes a number of Standards and Directories that provide detailed information on the construction, performance, application, ratings, and installation aspects of FMC.

#### **1.4.3.1 UL Standards**

The UL standard for the construction and performance of FMC is UL 1.

#### **1.4.3.2 UL Directories**

UL publishes several directories that contain useful information on the products that it lists, recognizes, and certifies. The directories are frequently used by installers and by inspection authorities to gain a better understanding of how to specify and install products in accordance with their listing. All of this information is also readily available at the UL website.

These directories are helpful tools for understanding the details of how products, in this case Flexible Metal Conduit, are constructed and marked as well as information on special or optional ratings, and terminations. One of the directories covers the UL approved methods for maintaining the fire resistive

rating on walls, floors, and ceilings for fire-resistance rated construction, when cables and conduits must penetrate them and be fire stopped.

**a) *UL General Information for Electrical Equipment Directory (commonly called White Book)***

The following information on FMC is reprinted from the *UL General Information for Electrical Equipment Directory*, with permission from Underwriters Laboratories Inc., Copyright © 2005 Underwriters Laboratories Inc.:

**FLEXIBLE METAL CONDUIT (DXUZ)**

**RELATED PRODUCTS**

For fittings see Conduit Fittings (DWTT).

**ADDITIONAL INFORMATION**

For additional information, see Electrical Equipment for Use in Ordinary Locations (AALZ).

**REQUIREMENTS**

The basic standard used to investigate products in this category is UL 1, "Flexible Metal Conduit."

**UL MARK**

The Listing Mark of Underwriters Laboratories Inc. on the attached tag, the reel or the smallest unit container in which the product is packaged with or without the UL symbol on the product is the only method provided by UL to identify products manufactured under its Listing and Follow-Up Service. The Listing Mark for these products includes the UL symbol (as illustrated in the Introduction of [the] Directory) together with the word "LISTED," a control number, and the product name as appropriate.

**b) *UL Electrical Construction Equipment Directory (commonly called Green Book)***

UL's *Electrical Construction Equipment Directory, Green Book*, contains the identical information that is contained in the *White Book* with the addition of the company name, address, and UL file number of those manufacturers that are authorized by Underwriters Laboratories to produce a listed product. The *Green Book* is frequently used to identify and locate manufacturers of listed FMC, to verify if a manufacturer is authorized to produce UL Listed FMC, and to identify the manufacturer of the conduit when the conduit is marked with the UL file number (E number) in place of the company name.

**c) *UL Fire Resistance Directory (commonly called Orange Book)***

UL's *Fire Resistance Directory* generally covers the construction detail necessary for constructing fire rated walls, floors, and ceilings. This directory also covers the listed materials and methods for sealing the wall ceiling or floor that has been penetrated by electrical cables, conduit, cable tray, or other equipment. The methods and materials are listed by UL under the category of "Through Penetration Fire Stop Systems." The Directory should always be consulted for the proper method of sealing the opening. Any such opening that is not properly sealed in accordance with the UL listed "Through Penetration Fire Stop Systems" will be subject to rejection by the inspecting authority.

**d) *UL Listing on Website***

Underwriters Laboratories operates a website at [www.ul.com](http://www.ul.com). This website contains an online version of the above directories as well as other general information relating to UL's products and services.

Once logged onto the UL website, go to the UL online certification directory. This will lead you to a list of product categories. The following list, or one similar, will be presented:

- [Company Name/Location](#)
- [UL File Number](#)

- [Appliance Wiring Material \(AWM\)](#)
- [Fire Resistance - Design or System Number](#)
- [Roofing Materials & Systems - Construction Number](#)
- [Building Materials - Assembly Number](#)
- [UL Category Control Number \(CCN\)/Guide Information](#)
- [Keyword Search](#)

The category should be chosen based on the information available to you. The keyword search is the easiest way to start if limited information is available. As an example, using “Flexible Metal Conduit” as the keyword opens the path to the information covered by the *UL Green Book* and *UL White Book Directories*.

## Section 2

### APPLICATION GUIDELINES FOR LIQUIDTIGHT FLEXIBLE METAL CONDUIT

#### 2.1 CONSTRUCTION

##### 2.1.1 General

Liquidtight Flexible Metal Conduit (LFMC) is constructed in accordance with the *National Electrical Code*<sup>®</sup> (*NEC*<sup>®</sup>) and complies with the safety requirements of *Underwriters Laboratories (UL) Standard for Safety for Liquidtight Flexible Metal Conduit*, UL 360.

##### 2.1.2 Conduit Core

The conduit is constructed with an interlocked zinc-coated corrosion-resistant steel in trade sizes 3/8, 1/2, 3/4, 1, 1-1/4, 1-1/2, 2, 2-1/2, 3, and 4. Conduit in trade sizes 3/8 – 1-1/4 includes a bonding strip or wire enclosed by the convolutions throughout its entire length. UL 360 specifies the requirements for the core's internal and external diameters, corrosion protection, electrical resistance, fault current carrying capability, flexibility, tension properties, and crush resistance, as well as pipe stiffness in the case of conduit intended for direct burial.

##### 2.1.3 Jacket

The jacket material is liquid-tight, nonmetallic, and sunlight resistant, suitable for use in wet, dry, or oily locations. The marked temperature designations indicate the maximum temperature for wet, dry, and oily locations. UL 360 governs the minimum jacket thickness.

##### 2.1.4 Fittings

Fittings for LFMC are constructed in accordance with UL 514B, *Conduit, Tubing and Cable Fittings*.

#### 2.2 GROUNDING

LFMC trade sizes 3/8, 1/2, 3/4, 1, and 1-1/4 may be used for equipment bonding in lengths of 6 ft or less when installed with listed fittings, and when installed in accordance with *NEC*<sup>®</sup> Article 350, Liquidtight Flexible Metal Conduit, and Article 250, Grounding and Bonding. LFMC trade sizes 3/8 through 4 may be installed in unlimited lengths provided the conduit meets the other requirements of Articles 350 and 250, and a separate grounding conductor is installed with the circuit conductors.

#### 2.3 MARKING

LFMC is marked with the manufacturer name or location, as well as trade size, temperature ratings, direct burial rating (where applicable), flame rating, and current ratings (when used for equipment bonding in accordance with Article 250).

#### 2.4 CODES AND STANDARDS

##### 2.4.1 *National Electrical Code*<sup>®</sup>

Type Liquidtight Flexible Metal Conduit, LFMC is designed, manufactured, and tested for use in accordance with the *National Electrical Code*<sup>®</sup>, Article 350 and UL 360.

##### 2.4.1.1 Uses permitted

*NEC*<sup>®</sup> Section 350.10 specifies the permitted uses of LFMC as follows:

*LFMC shall be permitted to be used in exposed and concealed locations as follows:*

- (1) Where conditions of installation, operation, or maintenance require flexibility or protection from liquids, vapors, or solids
- (2) As permitted by 501.10(B), 502.10, 503.10, and 504.20 and in other hazardous (classified) locations where specifically approved, and by 553.7(B)
- (3) For direct burial where listed and marked for the purpose

These permitted uses are not all-inclusive, but only provide guidance on where LFMC may be used.

In addition to permitted uses covered in Section 350.10, LFMC is permitted for installation as follows:

- Outside Branch Circuits and Feeders;
- Services;
- Under raised floors of computer rooms;
- Lighting whips; and
- Motor leads.

#### **2.4.1.2 Uses not permitted**

As with permitted uses, those uses not permitted by the *NEC*<sup>®</sup> are not all-inclusive. The Code language is intended to provide guidance on where and how LFMC may be used. *NEC*<sup>®</sup> Section 350.12 specifies the uses of LFMC that are not permitted, which are as follows:

- (1) Where subject to physical damage
- (2) Where any combination of ambient and conductor temperature produces an operating temperature in excess of that for which the material is approved

The following provides additional guidance on the uses of LFMC:

#### **Where subject to physical damage**

LFMC must be protected from physical damage. This includes installing LFMC at heights and locations where it will not be exposed to damage. It also includes providing mechanical protection such as from nails and screws in accordance with section 300.4(D) by maintaining a 1-1/4 in. (32 mm) distance from the edge of a framing member or by providing a metal plate where the distance cannot be maintained from the edge of a framing member or a furring strip.

#### **2.4.2 Related *NEC*<sup>®</sup> Articles**

The following *NEC*<sup>®</sup> Articles also contain provisions for the use of FMC:

##### **Wiring and Protection**

- ARTICLE 225 Outside Branch Circuits and Feeders  
225.10 Wiring on Buildings
- ARTICLE 230 Services  
230.43 Wiring Methods for 600 Volts, Nominal, or Less
- ARTICLE 250 Grounding and Bonding  
250.118 Types of Equipment Grounding Conductors

##### **Wiring Methods and Materials**

- ARTICLE 350 Liquidtight Flexible Metal Conduit: Type LFMC
- ARTICLE 368 Busways  
368.56 Branches from Busways
- ARTICLE 374 Cellular Metal Floor Raceways

- 374.11 Connection to Cabinets and Extensions from Cells
- ARTICLE 392 Cable Trays
  - 392.3 Uses Permitted (A) Wiring Methods

#### **Equipment for General Use**

- ARTICLE 430 Motors, Motor Circuits, and Controllers
  - XI. Over 600 Volts, Nominal
    - 430.223 Conductor Enclosures Adjacent to Motors
  - XIII. Grounding — All Voltages
    - 430.245 Method of Grounding
      - (B) Separation of Junction Box from Motor

#### **Special Occupancies**

- ARTICLE 501 Class I Locations
  - II. Wiring
    - 501.10 Wiring Methods`
      - (B) Class I, Division 2
        - (2) Flexible Connections
    - 501.30 Grounding and Bonding, Class I, Divisions 1 and 2
      - (B) Types of Equipment Grounding Conductors
- ARTICLE 502 Class II Locations
  - II. Wiring
    - 502.10 Wiring Methods
      - (2) Flexible Connections
    - 502.30 Grounding and Bonding, Class II, Divisions 1 and 2
      - (B) Types of Equipment Grounding Conductors
- ARTICLE 503 Class III Locations
  - II. Wiring
    - 503.10 Wiring Methods
      - (2) Flexible Connections
- ARTICLE 505 Class I, Zone 0, 1, and 2 Locations
  - 505.15 Wiring Methods
    - (C) Class I, Zone 2
      - (2) Flexible Connections
  - 505.25 Grounding and Bonding
    - (B) Types of Equipment Grounding Conductors
- ARTICLE 506 Zone 20, 21, and 22 Locations for Combustible Dusts, Fibers, and Flyings
  - 506.15 Wiring Methods (5)
  - 506.25 Grounding and Bonding
    - (B) Types of Equipment Grounding Conductors
- ARTICLE 511 Commercial Garages, Repair and Storage
  - 511.7 Wiring and Equipment Installed Above Class I Locations
    - (A) Wiring in Spaces Above Class I Locations
      - (1) Fixed Wiring Above Class I Locations
- ARTICLE 551 Recreational Vehicles and Recreational Vehicle Parks
  - IV. Nominal 120-Volt or 120/240-Volt Systems
    - 551.47 Wiring Methods
- ARTICLE 551 Recreational Vehicles and Recreational Vehicle Parks
  - VI. Recreational Vehicle Parks
    - 551.80 Underground Service, Feeder, Branch-Circuit, and Recreational Vehicle Site Feeder-Circuit Conductors
      - (B) Protection Against Physical Damage
- ARTICLE 552 Park Trailers
  - IV. Nominal 120-Volt or 120/240-Volt Systems

- 552.48 Wiring Methods
  - (A) Wiring Systems
- ARTICLE 553 Floating Buildings
  - II. Services and Feeders
    - 553.7 Installation of Services and Feeders
      - (B) Wiring Methods

### **Special Equipment**

- ARTICLE 600 Electric Signs and Outline Lighting
  - II. Field-Installed Skeleton Tubing
    - 600.31 Neon Secondary-Circuit Conductors, 1000 Volts or Less, Nominal
      - (A) Wiring Method
    - 600.32 Neon Secondary Circuit Conductors, Over 1000 Volts, Nominal
      - (A) Wiring Methods
        - (1) Installation
- ARTICLE 604 Manufactured Wiring Systems
  - 604.6 Construction
    - (A) Cable or Conduit Types
      - (2) Conduits
- ARTICLE 610 Cranes and Hoists
  - II. Wiring
    - 610.11 Wiring Method
      - (C) Flexible Connections to Motors and Similar Equipment
- ARTICLE 620 Elevators, Dumbwaiters, Escalators, Moving Walks, Wheelchair Lifts, and Stairway Chair Lifts
  - III. Wiring
    - 620.21 Wiring Methods
- ARTICLE 645 Information Technology Equipment
  - 645.5 Supply Circuits and Interconnecting Cables
    - (D) (2) Under Raised Floors
- ARTICLE 680 Swimming Pools, Fountains, and Similar Installations
  - II. Permanently Installed Pools
    - 680.23 Underwater Luminaires (Lighting Fixtures)
      - (F) Branch-Circuit Wiring
        - (1) Wiring Methods
  - IV. Spas and Hot Tubs
    - 680.42 Outdoor Installations
      - (A) Flexible Connections
        - (1) Flexible Conduit
- ARTICLE 695 Fire Pumps
  - 695.6 Power Wiring
    - (E) Pump Wiring
  - 695.14 Control Wiring
    - (E) Electric Fire Pump Control Wiring Methods

Reprinted with permission from NFPA 70-2005, the *National Electrical Code*<sup>®</sup>, © Copyright 2004, National Fire Protection Association, Quincy, MA 02269. This reprinted material is not the complete and official position of the NFPA on the referenced subject, which is represented only by the standard in its entirety.

### **2.4.3 Underwriters Laboratories (UL) Standards and Directories**

UL publishes a number of Standards and Directories that provides detailed information on the construction, performance, application, ratings, and installation aspects of LFMC.

### **2.4.3.1 UL Standards**

The UL standard for the construction and performance of LFMC is UL 360.

### **2.4.3.2 UL Directories**

UL publishes several directories that contain useful information on the products that it lists, recognizes, and certifies. The directories are frequently used by installers and by inspection authorities to gain a better understanding of how to specify and install products in accordance with their listing. All of this information is also readily available at the UL website.

These directories are helpful tools for understanding the details of how products, in this case Liquidtight Flexible Metal Conduit, are constructed and marked as well as information on special or optional ratings, and terminations. One of the directories covers the UL approved methods for maintaining the fire resistive rating on walls, floors, and ceilings for fire-resistance rated construction, when cables and conduits must penetrate them and be fire stopped.

#### **a) *UL General Information for Electrical Equipment Directory (commonly called White Book)***

The following information on LFMC is reprinted from the *UL General Information for Electrical Equipment Directory*, with permission from Underwriters Laboratories Inc., Copyright © 2005 Underwriters Laboratories Inc.:

#### **LIQUIDTIGHT FLEXIBLE METAL CONDUIT (DXHR)**

#### **RELATED PRODUCTS**

For fittings see Conduit Fittings (DWTT).

#### **ADDITIONAL INFORMATION**

For additional information, see Electrical Equipment for Use in Ordinary Locations (AALZ).

#### **REQUIREMENTS**

The basic standard used to investigate products in this category is UL 360, "Liquidtight Flexible Metal Conduit."

#### **UL MARK**

The Listing Mark of Underwriters Laboratories Inc. on the attached tag, the reel or the smallest unit container in which the product is packaged with or without the UL symbol on the product is the only method provided by UL to identify products manufactured under its Listing and Follow-Up Service. The Listing Mark for these products includes the UL symbol (as illustrated in the Introduction of [the] Directory) together with the word "LISTED," a control number, and the product name as appropriate.

#### **b) *UL Electrical Construction Equipment Directory (commonly called Green Book)***

UL's *Electrical Construction Equipment Directory, Green Book*, contains the identical information that is contained in the *White Book* with the addition of the company name, address, and UL file number of those manufacturers that are authorized by Underwriters Laboratories to produce a listed product. The *Green Book* is frequently used to identify and locate listed manufacturers of LFMC, to verify if a manufacturer is authorized to produce UL Listed LFMC, and to identify the manufacturer of the conduit when the conduit is marked with the UL file number (E number) in place of the company name.

#### **c) *UL Fire Resistance Directory (commonly called Orange Book)***

UL's *Fire Resistance Directory* generally covers the construction detail necessary for constructing fire rated walls, floors, and ceilings. This directory also covers the listed materials and methods for sealing the wall ceiling or floor that has been penetrated by electrical cables, conduit, cable tray, or other equipment. The methods and materials are listed by UL under the category of "Through Penetration Fire Stop Systems." The Directory should always be consulted for the proper method of sealing the opening.

Any such opening that is not properly sealed in accordance with the UL listed “Through Penetration Fire Stop Systems” will be subject to rejection by the inspecting authority.

**d) UL Listing on Website**

Underwriters Laboratories operates a website at [www.ul.com](http://www.ul.com). This website contains an online version of the above directories as well as other general information relating to UL’s products and services.

Once logged onto the UL website, go to UL on line certification directory. This will lead you to a list of product categories. The following list, or one similar, will be presented:

- [Company Name/Location](#)
- [UL File Number](#)
- [Appliance Wiring Material \(AWM\)](#)
- [Fire Resistance - Design or System Number](#)
- [Roofing Materials & Systems - Construction Number](#)
- [Building Materials - Assembly Number](#)
- [UL Category Control Number \(CCN\)/Guide Information](#)
- [Keyword Search](#)

The category should be chosen based on the information available to you. The key word search is the easiest way to start if limited information is available. As an example, using “Liquidtight Flexible metal Conduit” as the key word opens the path to the information covered by the *UL Green and White Book Directories*.

## Section 3 INSTALLATION GUIDELINES FOR FLEXIBLE METAL CONDUIT

### 3.1 INSTALLATION CONSIDERATIONS

#### 3.1.1 General

Typical installations provide for ease of connection utilizing straight, compound bend, vertical loop, lateral offset and other configurations. The *NEC*<sup>®</sup> specifies that the minimum centerline bend radius not be less than that listed in Table 2 of Chapter 9 under the "Other Bends" column. *NEC*<sup>®</sup> Sections 350.26 and 348.26 also require that there never be more than the equivalent of four 90-degree bends between pull points.

To reduce stress and the chance of fittings becoming loose from the conduit, it is recommended that a straight tangent length measured from the fitting, of 4 times the trade size diameter be established before creating a bend in the conduit. If possible, this distance should be secured with a restraint. This tangent length should also be considered when creating a vertical loop or lateral offset.

#### 3.1.2 Special Considerations for LFMC

Fittings for LFMC should always be mounted horizontally or from underneath termination boxes. This will allow all liquids to run away from the fittings. Fittings for LFMC should never be mounted on the top of boxes. This would allow liquids to flow through loose fittings into electrical boxes. To achieve maximum securement, fittings should be tightened to proper assembly torque values. Standard assembly torque values are located in Tables 1 and 2 of section 3.3 for FMC and LFMC respectively. Manufacturer's instructions should always be closely followed.

#### 3.1.3 Overall Length of Conduit

The following are calculations for determining the required overall length of conduit installed in a traveling vertical loop with offset. If there is no travel or offset, T and F in Figure 1 are equal to zero. It should be noted that these lengths do not include the length of fittings, as different types of fittings vary in length.

$$L = (8 \times TS) + (1.57 \times A) + T/2 + F$$

Where:

L = Overall length of conduit

TS= Trades size diameter

A = Horizontal distance between fittings\*

T = Travel distance

F = Offset

TL= Tangent Length (4 x TS)

\* Must be greater or equal to 2X the min. bending radius from *NEC*<sup>®</sup> Chapter 9, Table 2

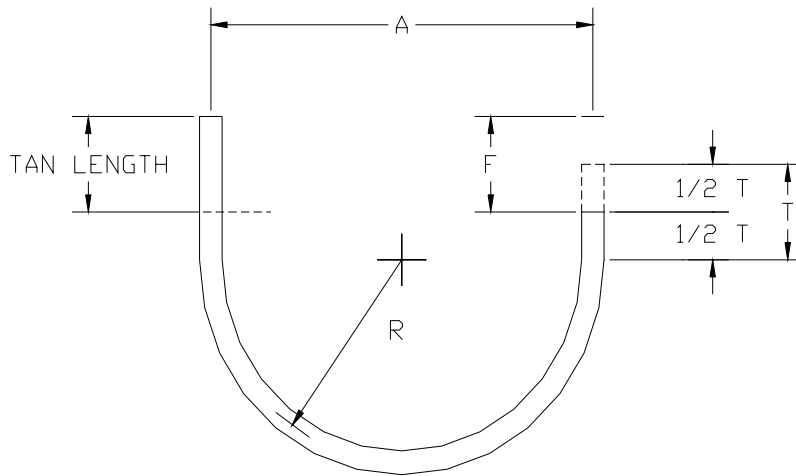

**Figure 1**  
**DETERMINATION OF OVERALL LENGTH OF CONDUIT INSTALLED IN A TRAVELING VERTICAL LOOP WITH OFFSET**

Overall lengths for lateral offset installations of FMC and LFMC are presented in Tables 3 through 8.

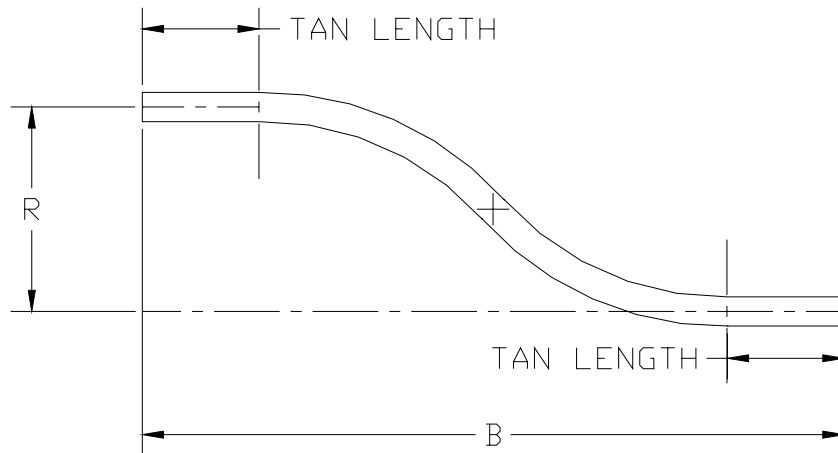

**Figure 2**  
**TANGENT LENGTH**

### 3.2 SECURING AND SUPPORTING FMC AND LFMC

According to *NEC*<sup>®</sup> Section 348.30 for FMC and Section 350.30 for LFMC, both conduits must be supported and secured at intervals of 4.5 ft (1.4 m) or less (unless routed through a framing member) and within 12 in. (300 mm) of every termination.

FMC and LFMC support requirements are waived when the conduit is fished, at terminals where flexibility is necessary, and where used for wiring luminaires.

### 3.2.1 Supporting

The *NEC*<sup>®</sup>, in Article 348 for FMC and Article 350 for LFMC, requires the conduit to be supported and secured at intervals not to exceed 1.4 m (4-1/2 ft) and within 300 mm (12 in.) of each box (note exceptions). Support in this manner ensures that a minimum strain will be placed on the conduit-to-fitting and fitting-to-box connection during assembly and throughout the lifetime of the installation. FMC and LFMC shall be supported at least at the frequency required by the *NEC*<sup>®</sup> using raceway supports intended for the purpose, and mounted by hardware acceptable to the authority having jurisdiction.

A variety of straps, clamps, and hangers that are specifically intended to secure FMC and LFMC and similar raceways are available. These supports shall be installed only on conduit of the trade size indicated on the support or its smallest unit shipping container. The variability of mounting surfaces, expected loads, and application environments will determine the appropriate support options and mounting hardware. Design specifications usually calculate requirements based on maximum spacing intervals given in the *NEC*<sup>®</sup>. Closer support intervals than are required in the *NEC*<sup>®</sup> are an acceptable option to heavier supports and mounting hardware in some applications.

### 3.2.2 Unsupported

The *NEC*<sup>®</sup> allows FMC and LFMC to be installed unsupported under the following conditions:

1. When the conduit is fished.
2. At terminals where flexibility is required in lengths not exceeding (3 ft) 900 mm for LFMC and lengths not exceeding the following for FMC:
  - (1) 3 ft (900 mm) for trade sizes 1/2 through 1-1/4 (metric designators 16 through 35)
  - (2) 4 ft (1200 mm) for trade sizes 1-1/2 through 2 (metric designators 41 through 53)
  - (3) 5 ft (1500 mm) for trade size 2-1/2 (metric designator 63) and larger
3. Lengths not exceeding 6 ft (1.8 m) from a luminaire (fixture) terminal connection for tap connections to luminaires (light fixtures) as permitted in 410.67(C).
4. Lengths not exceeding 6 ft (1.8 m) from the last point where the raceway is securely fastened for connections within an accessible ceiling to luminaire(s) [lighting fixture(s)] or other equipment.
5. In other than vertical runs through framing members where distance between members does not exceed 4.5 ft (1.4 m).

## 3.3 TERMINATING FLEXIBLE METAL CONDUIT

### 3.3.1 Fitting Selection

Selecting the correct fitting requires the installer to know:

- (1) The trade size or metric designator
- (2) The type of FMC: standard wall (FMC), reduced wall RWFMC, or extra-reduced wall (XRWFMC)
- (3) The type of metal either steel or aluminum

### 3.3.2 Conduit Preparation and Assembly

The most efficient assembly of a flexible metal conduit and fitting system can be achieved, and optimum performance ensured, by adherence to a few simple conduit preparation and assembly techniques.

- Square the cut end of the metal conduit.
- Insert conduit so that it is flush with the fitting's end stop.
- Ensure seating of clamp on conduit before torquing.
- Take care when torquing the fitting's securement screw(s).

For conduit preparation, always follow the conduit manufacturer's instructions. In addition, we recommend thorough adherence to the recommendations described in NEMA FB 2.20, *Selection and Installation*

*Guidelines for Fittings for use with Flexible Conduit and Cable.* This document can be downloaded free of charge from the NEMA website at [www.nema.org/stds/fb2-20.cfm](http://www.nema.org/stds/fb2-20.cfm).

The mechanical and electrical performance of a fitting for Flexible Metal Conduit is dependent on an adequate, secure, and clean bearing surface for the fitting's securement screw or clamp. Most experienced electricians recognize that flexible metal conduit is different on each end. Since the interlocked armor is wound in one direction, the convolutions on one end sometimes have a tendency to open when a fitting is tightened while the other end tends to remain more closed. Flexible Metal Conduit fittings are designed to assemble to either end of the conduit.

### **3.3.3 Cutting Conduit**

There are three methods used to cut sections of Flexible Metal Conduit, including rotary armor cutters, hacksaws, and wire cutters such as diagonal cutters. Rotary cutters are designed specifically for safely cutting Flexible Metal Conduit and Armored Cable. A few turns of the handle make a cut through the convolution. Where a hacksaw is used, a sharp hacksaw blade having at least 32 teeth per inch is recommended to cut one of the convolutions at approximately a 60-degree angle. The use of a wire cutter requires either breaking the armor or unwinding it. "Breaking the armor" involves bending the conduit at the point where the cut is desired and twisting the armor slightly so the cutting pliers can be inserted between the convolutions where it is cut. The armor must be twisted back into the convolutions before it is inserted into the connector.

Liquidtight Flexible Metal Conduit requires a square cut, which may be done with a sharp hacksaw with a blade equipped with at least 32 teeth per inch. A band saw may also be used with a 1/2" wide x .025" thick blade having 24 teeth per inch (no set) and a blade speed of approximately 350 ft per minute.

### **3.3.4 Inserting Conduit**

Product standards call for Flexible Metal Conduit connectors to have a smooth end stop that completely encircles the end of the conduit. For fittings that secure to the outside of the conduit, be certain that the conduit is completely inserted in the fitting and is flush against the end stop. This ensures that the conduit is secure, the sharp cut end of the conduit is bushed by the fitting, and the end of the conduit will not open under pressure when torquing the securement screw. When assembling a fitting that threads inside the conduit, be certain to fully thread the fitting until the conduit is flush against the external end stop of the fitting.

The diameter of the opening in the end stop of a listed fitting, of the type which secures to the outside of the conduit, is restricted based on the trade size of conduit for which it is listed. This requirement ensures effective bushing of the sharp end of the conduit and prevents it from being pulled through when the wires are pulled. Combination fittings listed for trade size 3/8 (12) flexible metal conduit as well as armored cable may have a smaller end stop diameter than a similar fitting specifically listed for armored cable. This can cause difficulty in feeding the conductors of larger sizes of armored cable within the fitting's acceptable range. Selection of the proper fitting to match the trade size of the conduit or cable cannot be overemphasized.

### **3.3.5 Seating a Securement Clamp**

Where a fitting employs a clamp as the means to secure the conduit, proper seating of the clamp to the conduit is to be ensured. Using the following method, the fitting's clamp will seat between the convolutions of the conduit:

Hand tighten the fitting screw(s). Then slightly rotate the conduit in the fitting. Where two screws are provided, they are to be alternately tightened until both are secure. The assembly shall then be visually inspected prior to applying the final torque to the screws to be certain the end of the conduit remains flush with the fitting's end stop (see Figure 3).

### 3.3.6 Tightening Torque

The designed performance of an FMC fitting is dependent on adequately torquing the fitting's securement means, screw or clamp. By nature of its design, the interlock construction of flexible metal conduit may be susceptible to collapse from overtightening of the fitting's securement means. Performance typically will not be enhanced and may be reduced when excessive torque is applied. The experienced electrician often has come to rely on the "measured by feel" approach when securing these fittings. Performance tests in the product standards prescribe testing under specific assembly torque (e.g. average hand tightening of a No. 10 screw with a screwdriver is represented by 35 lb-in. (3.96 N-m) torque). Some fitting designs include a raised screw boss. (See Figure 4.) It is usually not necessary or intended that the screw be tightened to the point that its head be in contact with the boss. The screws on certain fitting designs, particularly larger trade sizes, may offer more than one tightening option including screwdriver (slot, Phillips, or Robertson-square drive) and bolt head for wrench application (hex or square). Greater mechanical advantage and torque can generally be achieved with a wrench. Where both screwdriver and wrench application options are offered, torque should be limited to that which can be applied by the screwdriver. See Figure 5 for examples of FMC fittings having direct-bearing screws.

NEMA advocates the use of torque indicating tools for the assembly of FMC fittings. Care should be taken during fitting assembly not to puncture or deform the conduit, which may result in the presence of sharp edges in the wireway when wires are pulled. Table 1 provides a complete reference of standard assembly torques for FMC fittings. If a manufacturer prescribes a tightening torque other than that in the standard as a condition for listing, that recommended torque must be marked on installation instructions or the smallest unit shipping container in which the fitting is provided.

**Table 1**  
**STANDARD ASSEMBLY TORQUE VALUES FOR TYPE FMC FITTINGS**  
(Torque applied to test assemblies of listed fittings<sup>1</sup>)

Trade Size	Torque: lb-in. (N-m)				
	6	8	10	12	1/4+
Screws <sup>2</sup>	12 (1.38)	20 (2.26)	35 (3.96)	35 (3.96)	35 (3.96)
Bolt Head Screws <sup>3</sup>	—	—	—	160 (18.1)	160 (18.1)
Compression Gland Nut	—	—	—	—	—
Locknuts	—	—	—	—	—

<sup>1</sup> Test assemblies evaluated with alternative torque must be marked to indicate the manufacturer's recommended torque.

<sup>2</sup> Screwdriver applied (e.g. slotted, Phillips, Robertson-square drive head, or combinations). Also includes bolt head screws having provision for tightening with a screwdriver.

<sup>3</sup> Usually square or hexagonal, without provision for tightening with a screwdriver.

### 3.3.7 Attachment to Unthreaded Entries

Where Flexible Metal Conduit is used, electricians usually fasten the boxes into position on the framing members before attaching the raceway assembly. Conduit and fittings manufacturers caution installers to be sure to allow for sufficient length of conduit to enable complete seating of the conduit against the fittings end stop, so as to minimize undue stress on the conduit's interlocked convolutions and the conduit-to-fitting connection during attachment to a box. *NEC*<sup>®</sup> Section 300.18 requires that a raceway be completely installed and supported before conductors are pulled into it.

Flexible Metal Conduit fittings supplied with locknuts for attachment to a box or enclosure may be assembled first to either the conduit or the box; attachment first to the conduit is the preferred method. A secure attachment can be made when the locknut is hand tightened and then further tightened 1/4 turn using an appropriate tool. When securing the locknut, care is to be taken to avoid excessive pressure where gripping the body of the fitting is necessary. When tightening the locknut, the conduit and the body of the fitting are not to be rotated. Fittings supplied without locknuts are to be assembled to the conduit and the box according to the manufacturer's installation instructions.

NOTE—Locknuts are not to be relied upon to penetrate nonconductive coatings on enclosures. Such coatings are to be removed in the locknut area prior to raceway assembly to assure that a continuous ground path is achieved.

### **3.3.8 Attachment to Threaded Entries**

FMC connectors having external threads may be installed into the threaded entries provided in certain boxes, enclosures, and conduit bodies. This does not include external threads of fittings intended for insertion inside of conduit. (See Figure 6.) The external threads of FMC fittings conforming to ANSI/NEMA FB 1 have straight threads (NPS). Threaded openings where these may be installed may have taper (NPT) or straight (NPS) threads, varying depth, and number of threads. Care must be taken to ensure that a minimum of 3 threads of the connector are fully engaged with the threads of the conduit entry when wrench tightened.

### **3.3.9 Terminating Liquidtight Flexible Metal Conduit**

#### **3.3.9.1 Fitting Selection**

Selecting the correct fitting requires the installer to know:

- (1) The trade size or metric designator
- (2) The environment in which the conduit is to be installed (e.g. wet locations)

#### **3.3.9.2 Conduit Preparation and Assembly**

The most efficient assembly of a Liquidtight Flexible Metal Conduit and fitting system can be achieved, and optimum performance ensured, by adherence to a few simple conduit preparation and assembly techniques:

- Square the end of the conduit.
- Fully insert the conduit flush with the fitting's end stop.
- Ensure jacketing over conduit is not cut or ripped in any location.

For conduit preparation, always follow the conduit manufacturer's instructions. In addition, we recommend thorough adherence to the recommendations described in NEMA FB 2.20, *Selection and Installation Guidelines for Fittings for use with Flexible Conduit and Cable*. This document can be downloaded free of charge from the NEMA website at [www.nema.org/stds/fb2-20.cfm](http://www.nema.org/stds/fb2-20.cfm).

Start the assembly of the fitting to the liquidtight conduit by cutting the end of the conduit squarely using a hacksaw or similar tool. Liquidtight conduit manufacturers sometime offer cutting jigs specifically for this purpose. A hack saw blade should have 24-32 teeth per inch. A power band saw, when used, should be set at a speed no greater than 400 ft/min. The squared end of the conduit must be fully inserted onto the ferrule component of the fitting. (See Figure 7.) If the conduit is not cut squarely, complete seating of the conduit to the end of the ferrule cannot be assured. It is also important that the ferrule is inserted (screwed) all the way into the conduit to ensure proper seating of the sealing ring.

The remaining fitting components then must be securely assembled to the conduit. A compression gland nut, when supplied as part of a fitting, will typically achieve maximum securement when tightened to the assembly torque specified in Table 2 with an appropriate tool or in accordance with the manufacturer's instructions.

Assembly methods for LFMC fittings vary. Follow the manufacturer's directions closely.

To assure the integrity of the liquidtight system, the full length of the conduit should be examined for cuts or tears at the time of installation.

**Table 2**  
**STANDARD ASSEMBLY TORQUE VALUES FOR TYPE LFMC FITTINGS**

Trade size of fitting	Metric designator	Tightening Torque	
		lbf-in.	N-m
1/4	10	175	19.8
3/8	12	235	26.6
1/2	16	300	33.9
3/4	21	500	56.5
1	27	700	79.1
1-1/4	35	1000	113
1-1/2	41	1200	136
2	53	1600	181
2-1/2	63	1600	181
3	78	1600	181
3-1/2	91	1600	181
4	103	1600	181

### 3.3.9.3 Attachment to Unthreaded Entries

For installations where Liquidtight Flexible Metal Conduit is used, the electrician usually fastens the box or enclosure into position before attaching the conduit assembly. When the fitting and conduit assembly is to be attached to an unthreaded opening in a box or enclosure using a locknut, first attach the threaded body of the fittings to the box or enclosure and secure the locknut hand-tight. Then assemble the ferrule and gland nut onto the end of the conduit. After securely tightening the gland nut to the threaded body of the fittings, finish tightening the locknut.

A secure attachment to a box or enclosure can be made when the locknut is hand tightened and then further tightened 1/4 turn using an appropriate tool. When securing the locknut, care is to be taken to avoid excessive pressure where gripping the body of the fitting is necessary. The conduit and fitting body are not to be rotated when tightening the locknut.

NOTE—Locknuts are not to be relied upon to penetrate nonconductive coatings on enclosures. Such coatings are to be removed in the locknut area prior to raceway assembly to ensure a continuous ground path is achieved.

### 3.3.9.4 Attachment to Threaded Entries

LFMC fittings may be installed into the threaded entries provided in certain boxes, enclosures, and conduit bodies. Threaded openings may have either taper (NPT) or straight (NPS) threads, varying depth, and number of threads. Care should be taken to ensure that the threaded entry will accommodate a minimum of 3 engaged threads of the connector.

When assembling the fitting into a threaded enclosure, the body of the fitting is typically disassembled from the gland nut then threaded and wrench tightened into the enclosure entry. Teflon tape or lubricants should never be used on the threaded joint surfaces (unless specifically stated in the manufacturer's instructions). Doing so may result in a high impedance connection, which may interfere with the electrical ground continuity of the joint. After proper assembly of the fitting body to the enclosure, the remaining components of the assembly should then be joined to the conduit and then to the fitting's body, following the manufacturer's supplied instructions.

Conduit and fittings manufacturers caution installers to be sure to allow for sufficient length of conduit to enable complete seating of the conduit into the fitting's ferrule and so as not to put undue stress on the conduit-to-fitting connection during attachment to the box or enclosure.

### **3.4 VERIFICATION OF INSTALLATION**

Once the conduit is fully installed, a visual check should be made to determine if adjustments are needed. This is necessary to determine if there is any loosening of system components, which sometimes may occur during construction that involves other trades. The following steps should be taken:

- 1) Conduit shall be properly terminated at boxes.
- 2) Conduit shall be properly secured and supported.
- 3) Conduit shall not show evidence of damage or physical abuse.

**Table 3**  
**OVERALL CONDUIT LENGTH FOR GIVEN OFFSET AND LATERAL DISTANCE**  
**TRADE SIZE 1/2**

Lateral Distance "B" (inches)	"R" Offset Distance (inches)									
	1.0	1.5	2	2.5	3.0	4.0	5.0	6.0	8.0	10.0
5	5.6	—	—	—	—	—	—	—	—	—
6	6.3	6.7	—	—	—	—	—	—	—	—
7	7.2	7.5	7.8	8.2	—	—	—	—	—	—
8	8.2	8.4	8.6	9.0	9.4	—	—	—	—	—
9	9.1	9.3	9.5	9.8	10.1	10.9	—	—	—	—
10	10.1	10.2	10.4	10.7	11.0	11.6	12.5	—	—	—
11	11.1	11.2	11.4	11.6	11.8	12.4	13.2	14.0	—	—
12	12.1	12.2	12.3	12.5	12.7	13.3	13.9	14.7	16.6	—
13	13.1	13.2	13.3	13.5	13.6	14.1	14.7	15.5	17.2	—
14	14.1	14.1	14.3	14.4	14.6	15.0	15.6	16.2	17.8	19.7
15	15.1	15.1	15.2	15.4	15.5	15.9	16.5	17.1	18.5	20.3
20	20.0	20.1	20.2	20.3	20.4	20.7	21.0	21.5	22.5	23.9
25	25.0	25.1	25.1	25.2	25.3	25.5	25.8	26.1	27.0	28.0
30	30.0	30.0	30.1	30.2	30.2	30.4	30.6	30.9	31.6	32.5

**Table 4**  
**OVERALL CONDUIT LENGTH FOR GIVEN OFFSET AND LATERAL DISTANCE**  
**TRADE SIZE 3/4**

Lateral Distance "B" (inches)	"R" Offset Distance (inches)									
	1.0	1.5	2	2.5	3.0	4.0	5.0	6.0	8.0	10.0
7	7.6	—	—	—	—	—	—	—	—	—
8	8.3	8.7	—	—	—	—	—	—	—	—
9	9.2	9.5	9.8	—	—	—	—	—	—	—
10	10.2	10.4	10.6	11.0	—	—	—	—	—	—
11	11.1	11.3	11.5	11.8	—	—	—	—	—	—
12	12.1	12.2	12.4	12.7	13.0	—	—	—	—	—
13	13.1	13.2	13.4	13.6	13.8	14.4	—	—	—	—
14	14.1	14.2	14.3	14.5	14.7	15.3	—	—	—	—
15	15.1	15.2	15.3	15.5	15.6	16.1	16.7	—	—	—
20	20.0	20.1	20.2	20.3	20.4	20.7	21.2	21.7	22.9	24.4
25	25.0	25.1	25.1	25.2	25.3	25.6	25.9	26.2	27.2	28.3
30	30.0	30.1	30.1	30.2	30.2	30.4	30.7	31.0	31.7	32.7

**Table 5**  
**OVERALL CONDUIT LENGTH FOR GIVEN OFFSET AND LATERAL DISTANCE**  
**TRADE SIZE 1**

Lateral Distance "B" (inches)	"R" Offset Distance (inches)									
	1.0	1.5	2	2.5	3.0	4.0	5.0	6.0	8.0	10.0
9	9.6	—	—	—	—	—	—	—	—	—
10	10.3	10.7	—	—	—	—	—	—	—	—
11	11.2	11.5	11.8	—	—	—	—	—	—	—
12	12.2	12.4	12.6	13.0	—	—	—	—	—	—
13	13.1	13.3	13.5	13.8	14.1	—	—	—	—	—
14	14.1	14.2	14.4	14.7	15.0	15.6	—	—	—	—
15	15.1	15.2	15.4	15.6	15.8	16.4	17.2	—	—	—
20	20.1	20.1	20.2	20.3	20.5	20.9	21.3	21.9	23.3	24.9
25	25.0	25.1	25.2	25.2	25.3	25.6	26.0	26.4	27.4	28.7
30	30.0	30.1	30.1	30.2	30.3	30.5	30.7	31.1	31.9	32.9

**Table 6**  
**OVERALL CONDUIT LENGTH FOR GIVEN OFFSET AND LATERAL DISTANCE**  
**TRADE SIZE 1-1/4**

Lateral Distance "B" (inches)	"R" Offset Distance (inches)									
	1.0	1.5	2	2.5	3.0	4.0	5.0	6.0	8.0	10.0
11	11.6	—	—	—	—	—	—	—	—	—
12	12.3	12.7	—	—	—	—	—	—	—	—
13	13.2	13.5	13.8	—	—	—	—	—	—	—
14	14.2	14.4	14.6	—	—	—	—	—	—	—
15	15.1	15.3	15.5	15.8	—	—	—	—	—	—
16	16.1	16.2	16.4	16.7	—	—	—	—	—	—
17	17.1	17.2	17.4	17.6	17.8	—	—	—	—	—
18	18.1	18.2	18.3	18.5	18.7	19.3	—	—	—	—
19	19.1	19.2	19.3	19.5	19.6	20.1	20.7	—	—	—
20	20.1	20.1	20.3	20.4	20.6	21.0	21.6	22.2	—	—
25	25.0	25.1	25.2	25.3	25.4	25.7	26.1	26.5	27.7	29.1
30	30.0	30.1	30.1	30.2	30.3	30.5	30.8	31.2	32.1	33.2

**Table 7**  
**OVERALL LENGTH OF CONDUIT FOR GIVEN OFFSET AND LATERAL DISTANCE**  
**TRADE SIZE 1-1/2**

Lateral Distance "B" (inches)	"R" Offset Distance (inches)									
	1.0	1.5	2	2.5	3.0	4.0	5.0	6.0	8.0	10.0
13	13.6	—	—	—	—	—	—	—	—	—
14	14.3	—	—	—	—	—	—	—	—	—
15	15.2	15.5	—	—	—	—	—	—	—	—
16	16.2	16.4	16.6	—	—	—	—	—	—	—
17	17.1	17.3	17.5	17.8	—	—	—	—	—	—
18	18.1	18.2	18.4	18.7	19.0	—	—	—	—	—
19	19.1	19.2	19.4	19.6	19.8	—	—	—	—	—
20	20.1	20.2	20.3	20.5	20.7	21.3	—	—	—	—
25	25.0	25.1	25.2	25.3	25.5	25.8	26.2	26.8	—	—
30	30.0	30.1	30.1	30.2	30.3	30.6	30.9	31.3	32.3	33.5

**Table 8**  
**OVERALL LENGTH OF CONDUIT FOR GIVEN OFFSET AND LATERAL DISTANCE**  
**TRADE SIZE 2**

Lateral Distance "B" (inches)	"R" Offset Distance (inches)									
	1.0	1.5	2	2.5	3.0	4.0	5.0	6.0	8.0	10.0
17	17.6	—	—	—	—	—	—	—	—	—
18	18.3	18.7	—	—	—	—	—	—	—	—
19	19.2	19.5	19.8	20.2	—	—	—	—	—	—
20	20.2	20.4	20.6	21.0	21.4	—	—	—	—	—
22	22.1	22.2	22.4	22.7	23.0	23.6	—	—	—	—
24	24.1	24.2	24.3	24.5	24.7	25.3	25.9	—	—	—
26	26.1	26.1	26.3	26.4	26.6	27.0	27.6	28.2	—	—
28	28.1	28.1	28.2	28.3	28.5	28.9	29.3	29.9	31.3	—
30	30.0	30.1	30.2	30.3	30.4	30.7	31.2	31.7	32.9	34.4

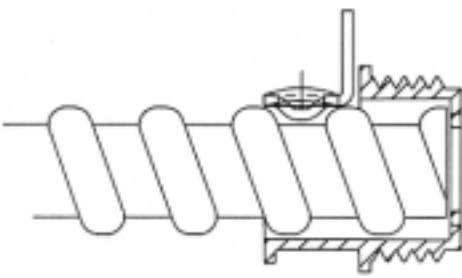

Correct Seating

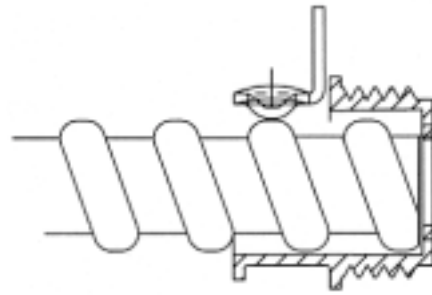

Incorrect Seating

**Figure 3**  
**FLEXIBLE METAL CONDUIT SECUREMENT CLAMP**



**FMC Squeeze Connector**



**FMC Single Screw Clamp Connector**



**FMC Connector (without locknut)**

**Screw Boss**



**FMC Duplex Connector (without locknut)**



**Twin Screw 90° Angle Connector**

**Figure 4**  
**TYPICAL DESIGNS OF FMC FITTINGS, CLAMP TYPE**

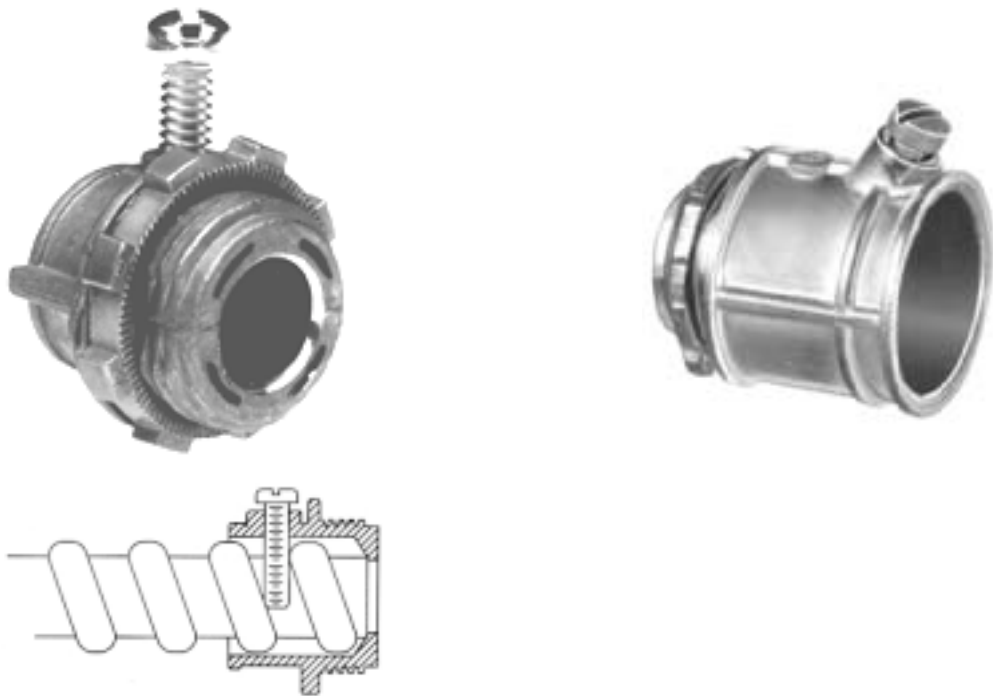

**Figure 5**  
**TYPICAL DESIGNS OF FMC FITTINGS, DIRECT-BEARING SCREW TYPE**



**Figure 6**  
**TYPICAL DESIGNS OF FMC FITTINGS, SCREW-IN TYPE**



**Annex A**  
**NEMA ENGINEERING BULLETIN NO. 93: LENGTH LIMITATIONS FOR FMC AND LFMC**



<b>ENGINEERING DEPARTMENT</b>
-------------------------------

# BULLETIN

**No. 93**  
April 2006

## Length Limitations for FMC and LFMC

The purpose of this Bulletin is to clarify the length limitations required by the National Electrical Code on Flexible Metal Conduit (FMC) and Liquid Tight Flexible Metal Conduit (LFMC).

Articles 348 and 350 of The National Electrical Code cover the installation requirements for FMC and LFMC. There is no length limitation specified for trade size 1/2 through 4 of either FMC or LFMC. Lengths of both FMC and LFMC trade size 3/8 are limited due to their use in specific installations specified in Section 348.20(A) and 350.20(A).

Some confusion exists on the permitted installed length of FMC and LFMC due to their use as an equipment grounding path as covered by NEC Section 250.118. Both FMC and LFMC may be used for equipment grounding under the specific conditions covered by NEC Section 250.118(6) for FMC and 250.118(7) for LFMC. One of these conditions requires that the total length of the ground path does not exceed 6 ft. However, this length limitation applies to the ground path, not the conduit. Where the length of the conduit exceeds 6 ft, an equipment grounding conductor must be used.

In summary, the only length limitation specified by the NEC on the installation of FMC and LFMC is where trade size 3/8 is used for specific installations specified in NEC Sections 348.20(A) for FMC and 350.20(A) for LFMC. All other trade sizes have no length limitation.

§